

ONKYO®

Audio Video Control Amplifier

A-DS650

Instruction Manual

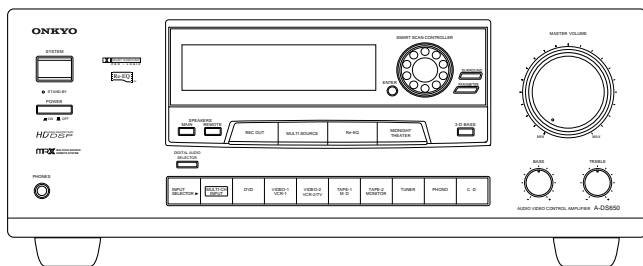

Thank you for purchasing the Onkyo Audio Video Control Amplifier.

Please read this manual thoroughly before making connections and turning on the power.

Following the instructions in this manual will enable you to obtain optimum performance and listening enjoyment from your new Audio Video Control Amplifier.

Please retain this manual for future reference.

Contents

Before using

Important Safeguards.....	2
Precautions	3
Features.....	4
Supplied accessories.....	4
Introduction	5
Before operating this unit.....	6

Preparation

Audio equipment connections	7
Video equipment connections	8
Making speaker connections	11
AC outlet connections	13
Connecting the power.....	13
Speaker system setup.....	14

Operation

Basic operation	16
Using Surround mode.....	20
Recording a source	24
Using TAPE-2 MONITOR.....	25
Programming remote controller codes	26
Connection for multiple-room remote control.....	28
Listening in another room	29

A few important notes

Troubleshooting guide.....	30
Specifications	31
Control positions and names	32
Remote controller RC-374M.....	33

WARNING:

TO REDUCE THE RISK OF FIRE OR ELECTRIC SHOCK, DO NOT EXPOSE THIS APPLIANCE TO RAIN OR MOISTURE.

CAUTION:

TO REDUCE THE RISK OF ELECTRIC SHOCK, DO NOT REMOVE COVER (OR BACK). NO USER-SERVICEABLE PARTS INSIDE. REFER SERVICING TO QUALIFIED SERVICE PERSONNEL.



WARNING
RISK OF ELECTRIC SHOCK
DO NOT OPEN

AVIS
RISQUE DE CHOC ELECTRIQUE
NE PAS OUVRIE



The lightning flash with arrowhead symbol, within an equilateral triangle, is intended to alert the user to the presence of uninsulated "dangerous voltage" within the product's enclosure that may be of sufficient magnitude to constitute a risk of electric shock to persons.



The exclamation point within an equilateral triangle is intended to alert the user to the presence of important operating and maintenance (servicing) instructions in the literature accompanying the appliance.

Important Safeguards

1. **Read Instructions** – All the safety and operating instructions should be read before the appliance is operated.
2. **Retain Instructions** – The safety and operating instructions should be retained for future reference.
3. **Heed Warnings** – All warnings on the appliance and in the operating instructions should be adhered to.
4. **Follow Instructions** – All operating and use instructions should be followed.
5. **Water and Moisture** – The appliance should not be used near water – for example, near a bathtub, washbowl, kitchen sink, laundry tub, in a wet basement, or near a swimming pool, and the like.
6. **Carts and Stands** – The appliance should be used only with a cart or stand that is recommended by the manufacturer.

PORTABLE CART WARNING



S3125A
- 6A. An appliance and cart combination should be moved with care. Quick stops, excessive force, and uneven surfaces may cause the appliance and cart combination to overturn.
7. **Wall or Ceiling Mounting** – The appliance should be mounted to a wall or ceiling only as recommended by the manufacturer.
8. **Ventilation** – The appliance should be situated so that its location or position does not interfere with its proper ventilation. For example, the appliance should not be situated on a bed, sofa, rug, or similar surface that may block the ventilation openings; or if placed in a built-in installation, such as a bookcase or cabinet that may impede the flow of air through the ventilation openings, there should be free space of at least 20 cm (8 in.) and an opening behind the appliance.
9. **Heat** – The appliance should be situated away from heat sources such as radiators, heat registers, stoves, or other appliances (including amplifiers) that produce heat.
10. **Power Sources** – The appliance should be connected to a power supply only of the type described in the operating instructions or as marked on the appliance.
11. **Polarization** – If the appliance is provided with a polarized plug having one blade wider than the other, please read the following information:
The polarization of the plug is a safety feature. The polarized plug will only fit the outlet one way. If the plug does not fit fully into the outlet, try reversing it. If there is still trouble, the user should seek the services of a qualified electrician. Under no circumstances should the user attempt to defeat the polarization of the plug.
12. **Power-Cord Protection** – Power-supply cords should be routed so that they are not likely to be walked on or pinched by items placed upon or against them, especially near plugs, convenience receptacles, and the point where they exit from the appliance.
13. **Cleaning** – The appliance should be cleaned only as recommended by the manufacturer.
14. **Nonuse Periods** – The power cord of the appliance should be unplugged from the outlet when left unused for a long period of time.
15. **Object and Liquid Entry** – Care should be taken so that objects do not fall and liquids are not spilled into the enclosure through openings.
16. **Damage Requiring Service** – The appliance should be serviced by qualified service personnel when:
 - A. The power-supply cord or the plug has been damaged; or
 - B. Objects have fallen, or liquid has been spilled into the appliance; or
 - C. The appliance has been exposed to rain; or
 - D. The appliance does not appear to operate normally or exhibits a marked change in performance; or
 - E. The appliance has been dropped, or the enclosure damaged.
17. **Servicing** – The user should not attempt to service the appliance beyond that described in the operating instructions. All other servicing should be referred to qualified service personnel.

Precautions

1. Warranty Claim

You can find the serial number on the rear panel of this unit. In case of warranty claim, please report this number.

2. Recording Copyright

Recording of copyrighted material for other than personal use is illegal without permission of the copyright holder.

3. AC Fuse

The fuse is located inside the chassis and is not user-serviceable. If power does not come on, contact your Onkyo authorized service station.

4. Care

From time to time you should wipe the front and rear panels and the cabinet with a soft cloth. For heavier dirt, dampen a soft cloth in a weak solution of mild detergent and water, wring it out dry, and wipe off the dirt. Following this, dry immediately with a clean cloth. Do not use rough material, thinners, alcohol or other chemical solvents or cloths since these could damage the finish or remove the panel lettering.

5. Power

WARNING

BEFORE PLUGGING IN THE UNIT FOR THE FIRST TIME, READ THE FOLLOWING SECTION CAREFULLY.

- The voltage of the available power supply differs according to country or region. Be sure that the power supply voltage of the area where this unit will be used meets the required voltage (e.g., AC 230 V 50 Hz or AC 120 V 60 Hz) written on the rear panel.
- Models Equipped with a Voltage Selector
Worldwide models are equipped with a voltage selector to conform to local power supplies. Be sure to set this switch to match the voltage of the power supply in your area before plugging in the unit.

For British model

Replacement and mounting of an AC plug on the power supply cord of this unit should be performed only by qualified service personnel.

• IMPORTANT

The wires in the mains lead are coloured in accordance with the following code:

- Blue : Neutral
- Brown : Live

As the colours of the wires in the mains lead of this apparatus may not correspond with the coloured markings identifying the terminals in your plug, proceed as follows:

The wire which is coloured blue must be connected to the terminal which is marked with the letter N or coloured black.

The wire which is coloured brown must be connected to the terminal which is marked with the letter L or coloured red.

• IMPORTANT

A 5 amp fuse is fitted in this plug. Should the fuse need to be replaced, please ensure that the replacement fuse has a rating of 5 amps and that it is approved by ASTA or BSI to BS1362. Check for the ASTA mark or the BSI mark on the body of the fuse.

IF THE FITTED MOULDED PLUG IS UNSUITABLE FOR THE SOCKET OUTLET IN YOUR HOME THEN THE FUSE SHOULD BE REMOVED AND THE PLUG CUT OFF AND DISPOSED OF SAFELY. THERE IS A DANGER OF SEVERE ELECTRICAL SHOCK IF THE CUT OFF PLUG IS INSERTED INTO ANY 13 AMP SOCKET.

If in any doubt, please consult a qualified electrician.

For U.S. model

Note to CATV system installer:

This reminder is provided to call the CATV system installer's attention to Section 820-40 of the NEC which provides guidelines for proper grounding and, in particular, specifies that the cable ground shall be connected to the grounding system of the building, as close to the point of cable entry as practical.

FCC Information for User

CAUTION:

Changes or modifications not expressly approved by the manufacturer for compliance could void the user's authority to operate the equipment.

NOTE:

This equipment has been tested and found to comply with the limits for a Class B digital device, pursuant to Part 15 of the FCC Rules. These limits are designed to provide reasonable protection against harmful interference in a residential installation. This equipment generates, uses, and can radiate radio frequency energy and, if not installed and used in accordance with the instructions, may cause harmful interference to radio communications. However, there is no guarantee that interference will not occur in a particular installation. If this equipment does cause harmful interference to radio or television reception, which can be determined by turning the equipment off and on, the user is encouraged to try to correct the interference by one or more of the following measures:

- Reorient or relocate the receiving antenna.
- Increase the separation between other equipment and the receiver.
- Connect the equipment into an outlet on a circuit different from that to which the receiver is connected.
- Consult the dealer or an experienced radio/TV technician for help.

For Canadian model

Modele pour les Canadien

- For models having a power cord with a polarized plug:

CAUTION: TO PREVENT ELECTRIC SHOCK, MATCH WIDE BLADE OF PLUG TO WIDE SLOT, FULLY INSERT.

THIS DIGITAL APPARATUS DOES NOT EXCEED THE CLASS B LIMITS FOR RADIO NOISE EMISSION FROM DIGITAL APPARATUS SET OUT IN THE RADIO INTERFERENCE REGULATIONS OF THE CANADIAN DEPARTMENT OF COMMUNICATIONS.

- Sur les modèles dont la fiche est polarisée:

ATTENTION: POUR ÉVITER LES CHOCS ÉLECTRIQUES, INTRODUIRE LA LAME LA PLUS LARGE DE LA FICHE DANS LA BORNE CORRESPONDANTE DE LA PRISE ET POUSSER JUSQU'AU FOND.

L'INTERFÉRENCE RADIO ÉLECTRIQUE GÉNÉRÉE PAR CET APPAREIL NUMÉRIQUE DE TYPE B NE DÉPASSE PAS LES LIMITES ÉNONCÉES DANS LE RÈGLEMENT SUR LES PERTURBATIONS RADIO ÉLECTRIQUES, SECTION APPAREIL NUMÉRIQUE, DU MINISTÈRE DES COMMUNICATIONS.

For European model

Declaration of Conformity

We, ONKYO EUROPE ELECTRONICS GmbH
INDUSTRIESTRASSE 20
82110 GERMERING,
GERMANY



declare in own responsibility, that the ONKYO product described in this instruction manual is in compliance with the corresponding technical standards such as EN55013, EN55020, EN61000-3-2, -3-3 and EN60065

GERMERING, GERMANY

K. OTSU

ONKYO EUROPE ELECTRONICS GmbH

Features

Amplifier Features

- EUROPEAN MODELS: 100 Watts minimum of continuous RMS power to each of the five channels into 6Ω, 1,000 Hz, DIN
- ASIAN MODELS: 130 Watts minimum of continuous RMS power to each of the five channels into 6Ω, 1 kHz, EIAJ
- POWERFUL HIGH-CURRENT, LOW-IMPEDANCE DRIVE AMPLIFIERS for each of the 5 channels, with discrete output stages—no inexpensive ICs—assures that no channel information is compromised, and handles the wide dynamics of 5.1 channel movie soundtracks cleanly and effortlessly
- LOW NEGATIVE FEEDBACK, WIDEBAND CIRCUITRY minimizes noise and distortion
- HIGH RESOLUTION 20-BIT DELTA SIGMA D/A AND A/D CONVERTERS for greater precision
- 3-D BASS lets you boost ultra-low frequencies to the front 3 channels, for bass with greater clarity and impact

Audio/Video Features

- DOLBY* DIGITAL PROCESSOR BUILT-IN to decode the 5.1 channel pristine digital audio on DVDs, HDTV and other sources
- 5.1 CHANNEL EXTERNAL INPUTS gives you the option of connecting an additional 5.1 channel decoder for DTS, MPEG and upcoming formats
- CINEMA RE-EQ™ CIRCUITRY** takes the edginess or “brightness” out of home cinema sound, compensating for the fact that sound mixed for theaters will sound too bright when played back through flat response in the home
- 6 SURROUND MODES: Dolby Digital, Dolby Pro Logic, Hall, Live, Arena and Studio, with user-adjustable parameters for each mode, including venue size, effect and reverb levels, and reverb time
- LATEST-GENERATION MOTOROLA 24-BIT CHIP, the DSP56009, runs at 88 MHz, and can execute 44 million instructions per second (MIPS) for greater processing capacity that translates into better dynamics, more reflections and more reverberations—parameters that define how real everything will sound—also gives you more control over factors exclusive to your home theaters, such as room size, ambiance, equalization and time delay
- IPM—Intelligent Power Management for powering up entire system and delivering surround sound whenever TV is turned on (audio triggered)

General Features

- MULTIRoom/MULTISOURCE CAPABILITY with Main/Remote speaker selector and outputs to play two different sources simultaneously without the need of an additional amplifier
- LARGE 35-SEGMENT DOT-MATRIX FLUORESCENT DISPLAY for more refined, natural-looking numbers and letters that are easier to read, and to make system status easy to see from across the room
- 3-MODE DIMMER (bright, normal, low) to match the ambience of any room lighting situation for maximum home theater enjoyment (operated by remote)
- AUDIO MUTE (remote) instantly switches off the sound—convenient for phone calls, and for recording without listening
- SLEEP TIMER (remote) shuts down system after 10 to 90 minutes (10 min. steps)
- BATTERY-FREE MEMORY BACKUP protects memory's contents during a power outage or if the unit is temporarily unplugged

*Manufactured under license from Dolby Laboratories.

“Dolby”, “Pro Logic” and the double-D symbol  are trademarks of Dolby Laboratories. Confidential Unpublished Works. ©1992-1997 Dolby Laboratories, Inc. All rights reserved.

** Re-Equalization™ is a trademark of Lucasfilm Ltd.

Supplied accessories

Check that the following accessories are supplied with this unit. The number of each supplied accessory is indicated in parentheses.

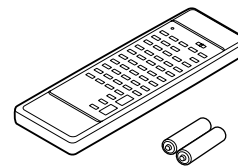

Remote controller (RC-374M) (1)
Batteries (size AA, R6, or UM-3) (2)

The following accessories are available only for worldwide models.

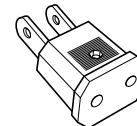

CV plug (Shape may vary depending on the area in which it was purchased.) (1)

Memory Preservation

This unit does not require memory preservation batteries. A built-in memory power back-up system preserves the contents of the memory during power failures and even when the unit is unplugged. The unit must be plugged-in in order to charge the back-up system.

The memory preservation period after the unit has been unplugged varies depending on climate and placement of the unit. On the average, memory contents are protected over a period of a few weeks after the last time the unit was unplugged. This period is shorter when the unit is exposed to a highly humid climate.

Introduction

Surround System

Since the A-DS650 is equipped with front, center, and Surround amplifiers, you can produce Dolby Digital, Dolby Pro Logic, Hall, Live, Arena, and Studio Surround effects. You can enjoy the feeling of a movie theater or concert hall in your own living room.

Dolby Digital

Dolby Digital is a new-generation digital audio format for multi-channel Surround audio. With this digital audio format, you can create a five full-range channel system that is a developed version of the conventional Surround system (left, center, right, and Surround channel).

Adding to its five full-range channels, Dolby Digital supports an LFE (low frequency effect) channel, which is used solely for low frequency sounds independent of the other channels.

Dolby Digital is sometimes referred to as a "5.1" channel format since this LFE channel is indicated as 0.1.

This fully discrete 5.1 channel Dolby Digital can reproduce the sound of a wide and dynamic range, transforming your room into a home theater.

Dolby Digital technology is implemented in such media as laser discs, DVDs (digital video discs), CATV (cable television), DBS (direct broadcasting satellite).

By using CATV or the proper equipment for the playback of laser discs bearing the  trademark, you can recreate in your own living room the feeling of watching a movie in a top-quality theater.

DOLBY PRO LOGIC Surround

Many motion pictures have been released in 4-channel "Dolby Stereo" sound, with music, dialogue, and panned effects coming from the 3-channel front soundstage, and surround effects and ambience emanating from the sides and rear of the theater.

The motion picture masters are used for production of stereo VHS, VHS-Hi-Fi, Beta Hi-Fi, and stereo laser discs that you can buy or rent at your video store. The A-DS650 incorporates the Digital Dolby Pro Logic Surround Circuit, which is designed to decode the four-channel audience experience found in DOLBY STEREO movies. Dolby Pro Logic Surround is capable of recreating a multi-dimensional soundstage, but with the increased channel separation it gives a far greater sense of "movement" and sound localization. Just like in the theater, the addition of the active center channel ensures that all audience members hear dialogue coming from its on-screen sources, regardless of seating position.

HALL Surround

This mode is especially suitable for media that already has a substantial amount of reverb sound, such as classical music, since it simulates the atmosphere of a concert hall.

LIVE Surround

This mode reproduces the feeling of a live performance.

ARENA Surround

This mode recreates the mood of listening to a concert in a domed stadium.

STUDIO Surround

This mode is good for studio recordings that may have few reverb sounds such as pop and jazz.

DSP (Digital Signal Processor)

The DSP converts the musical signal into digital form and produces reflected sound from the digital signal. This is applied to the musical signal to yield an effect approaching that of a live performance.

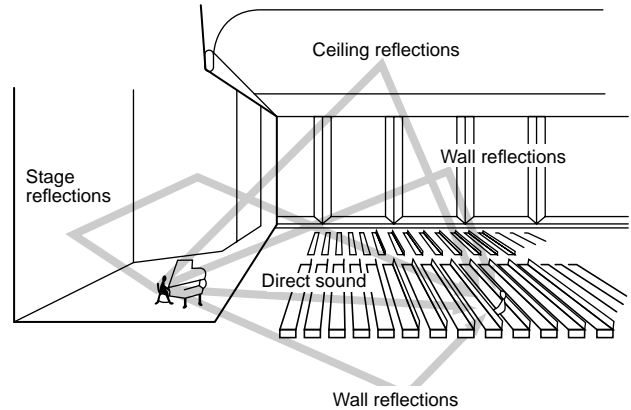

NOTES:

- The concert hall effect is produced from the reflections and reverberations contained in the original recording. These are converted into reflected sound that is reproduced from four directions. Thus, in some cases an unnatural impression can be conveyed if there are too few reflections in the recording or if the effects in the original recording were produced artificially.
- The concert hall effect is not merely an artificial reverberation unit, but a sophisticated effect that spreads existing reverberation around.

Multi-Room Remote System (MRX)

Using the Multi-Room Remote System equipment, you can operate all components connected to the A-DS650 from either the main room or the sub-room. (Refer to page 28 for more details).

The following equipment (sold separately) is essential for using the Onkyo Multi-Room System:

- * Sensor Unit: Model No. HR-10
- * Remote Emitter: Model No. HE-50 (AC)
- * Remote Emitter Head: Model No. HE-10

The following secondary remote controller can be used to operate the system from the sub-room:

- * Secondary Remote Controller for Multi-Room Remote System: Model No. RC-MR1H

Before operating this unit

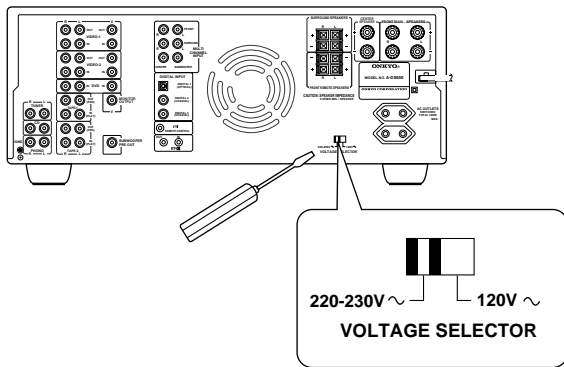

Setting the Voltage selector (Worldwide models only)

Worldwide models are equipped with a voltage selector to conform with local power supplies. Be sure to set this switch to match the voltage of the power supply in your area before plugging in the unit.

1. Determine the proper voltage for your area: 220-230V or 120V.
2. If the preset voltage is not correct for your area, insert a screwdriver into the groove in the switch. Slide the switch all the way to the right (120V) or to the left (220-230V), whichever is appropriate.

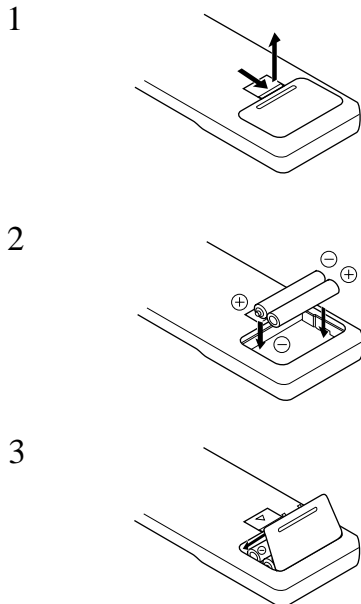

Installing the batteries

1. Remove the battery compartment cover by pressing and sliding it out.
2. Insert two AA (R6- or UM-3)-size batteries into the battery compartment. Carefully follow the polarity diagram (positive (+) and negative (-) symbols) inside the battery compartment.
3. After batteries are installed and seated correctly, replace the compartment cover.

- If the battery voltage is low, the indicator on the remote controller will not flash when you press any button on the controller.

Remove low-voltage batteries immediately to avoid damage due to corrosion. Never mix old and new batteries.

- The learned codes are retained, even when the batteries are replaced.

They may be lost, however, if battery replacement is not completed within one hour. In this case, the unit must learn the codes again.

- The manganese batteries supplied with this unit have a service life of approximately six months, depending on the frequency of use.
- Use spare batteries of the type specified in the table below.

Type	Voltage	Size
Manganese or Alkaline	1.5V	AA, R6 (UM-3) or LR6 (AM-3)

We recommend that long-life AA (LR6 or AM-3) size alkaline batteries be used.

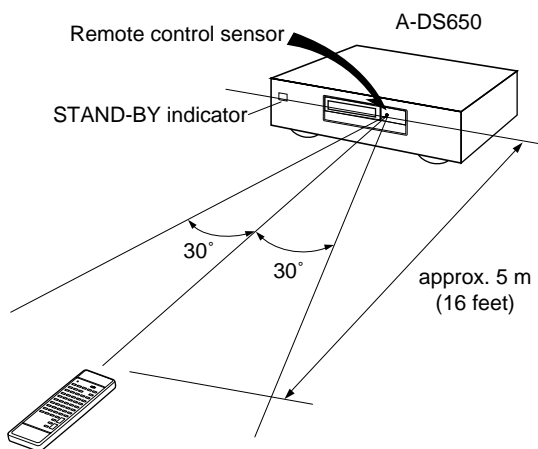

Using the remote controller

The STAND-BY indicator lights up when the unit receives a signal from the remote controller.

The following information will help you get optimal use from the remote controller.

- Place this amplifier away from direct bright light, which could prevent proper operation of the remote control.
- Make sure audio rack doors do not have tinted glass. Placing the amplifier behind such a door may prevent proper remote controller operation.
- Using other remote controllers along with the amplifier's remote controller in the same room may cause interference.

Audio equipment connections

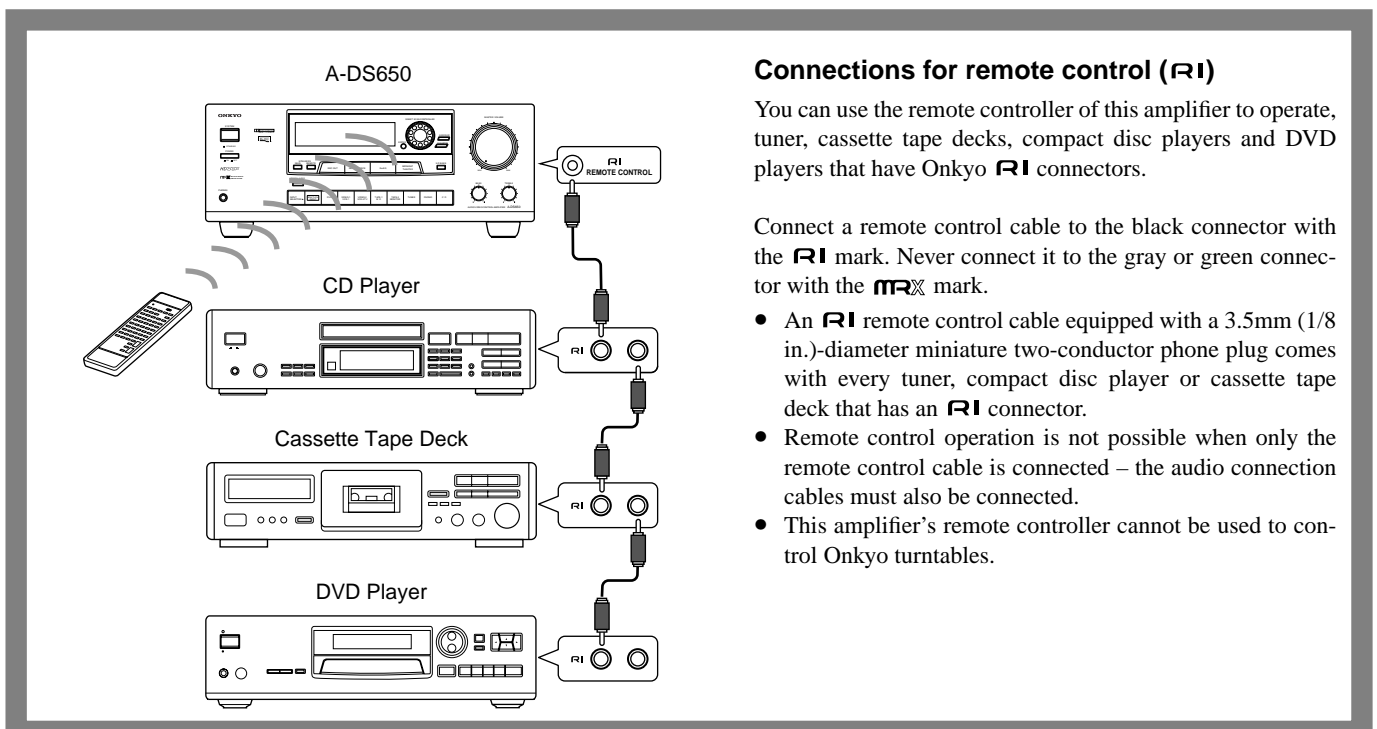
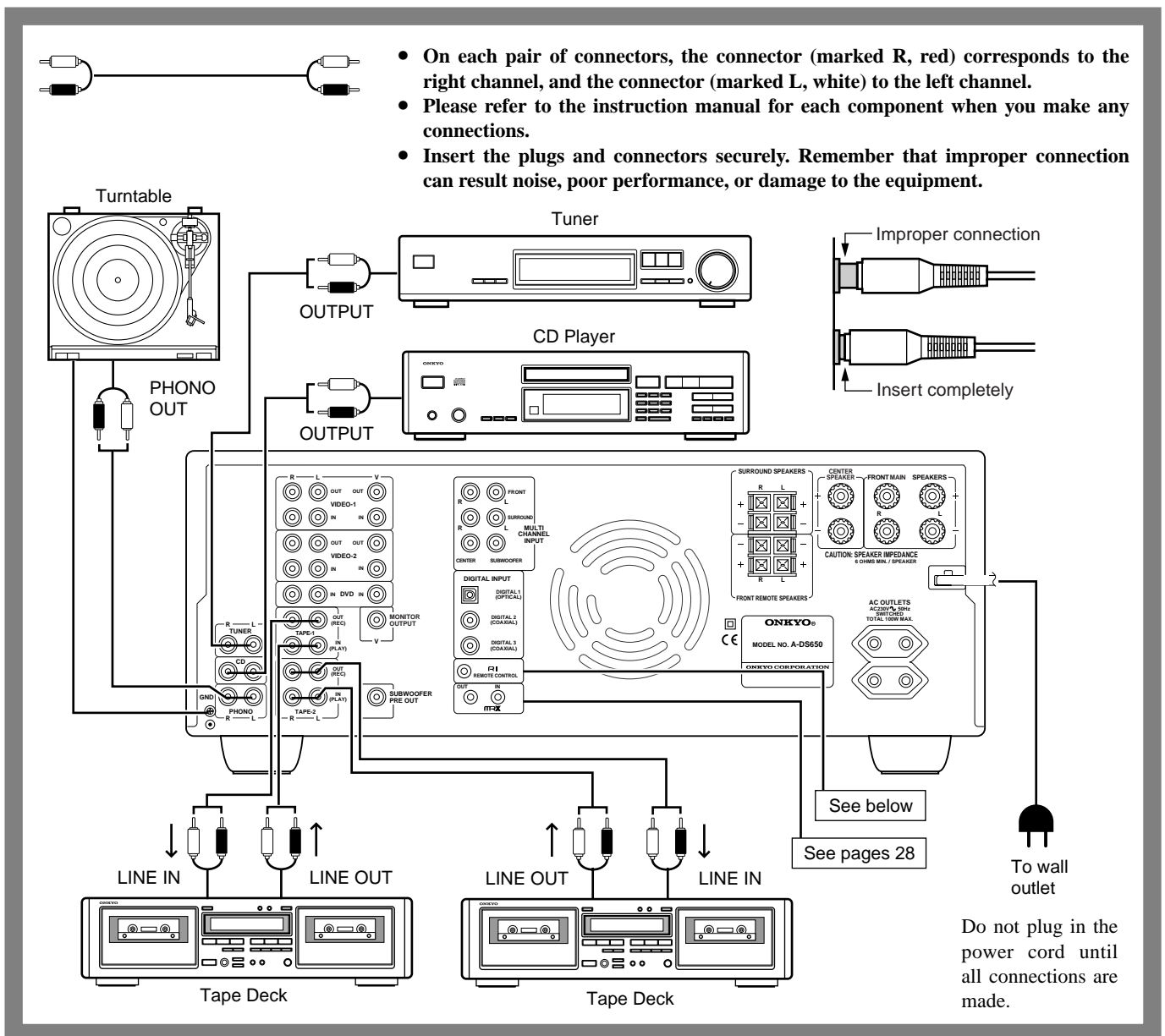

Video equipment connections

Digital audio connections

The A-DS650 amplifier has a powerful digital signal processor for use with DVD players, DAT decks, and CD players. The digital inputs, DIGITAL-1, DIGITAL-2, and DIGITAL-3, can be assigned to individual input selector buttons, so when an input selector button is pressed, the assigned digital input is used instead of the corresponding analog input. (See page 17.)

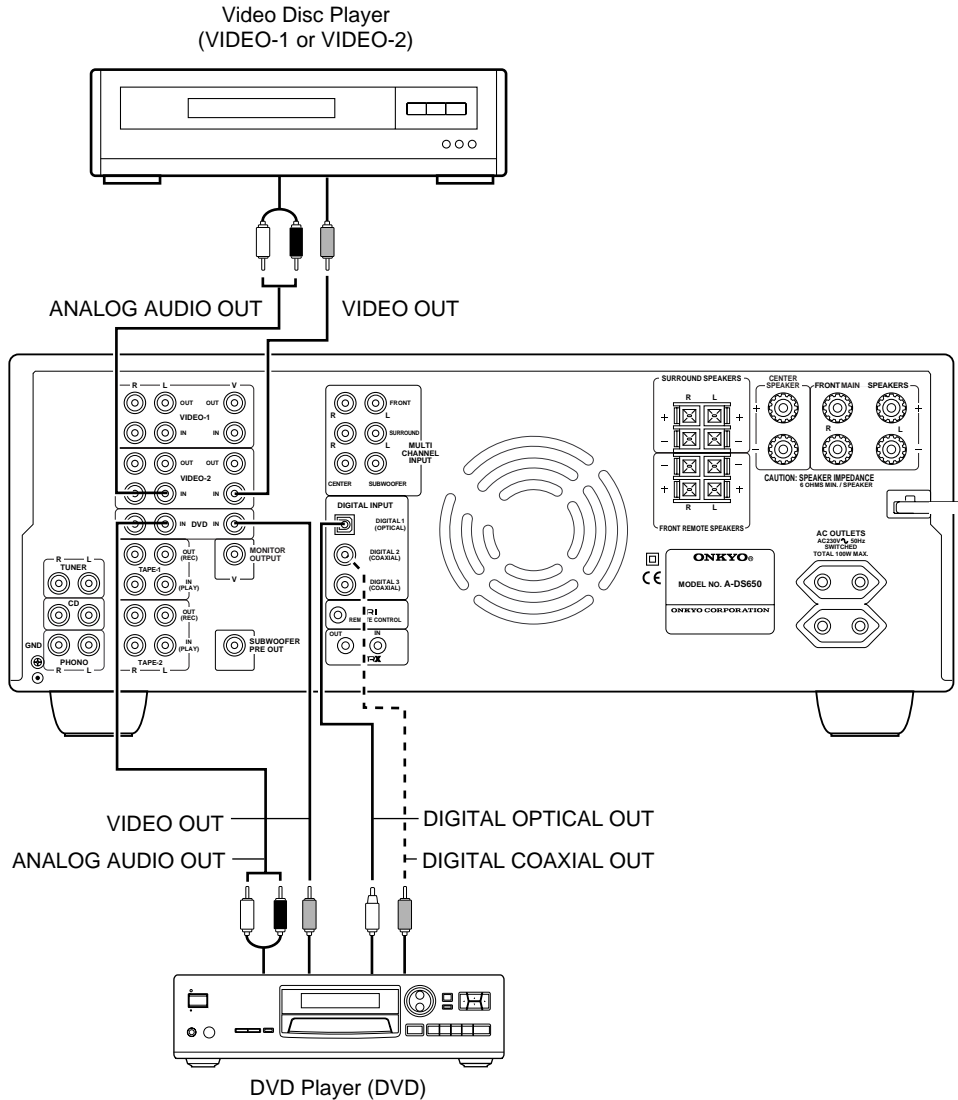

- A DVD or other component equipped with a digital output can be connected to the A-DS650. The digital connection must be used in conjunction with an analog connection, because if the analog cable is disconnected, the multi-room remote system, TAPE OUT and REC OUTs, and headphone will not work.
- When you connect a VCR, etc. to the VIDEO-2 R/L jacks, you must turn the IPM function off (see page 10 for information on the IPM system).
- Remove the protective cap attached to the DIGITAL-1 (OPTICAL) terminal before making connection. When this terminal is not use, replace the protective cap.

Video equipment connections

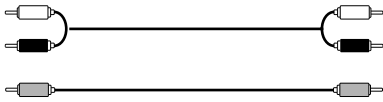

- On each pair of connectors, the connector (marked R, red) corresponds to the right channel, and the connector (marked L, white) to the left channel.
- The yellow connector (marked V) is used for video connection.
- Please refer to the instruction manual for each component when you make any connections.

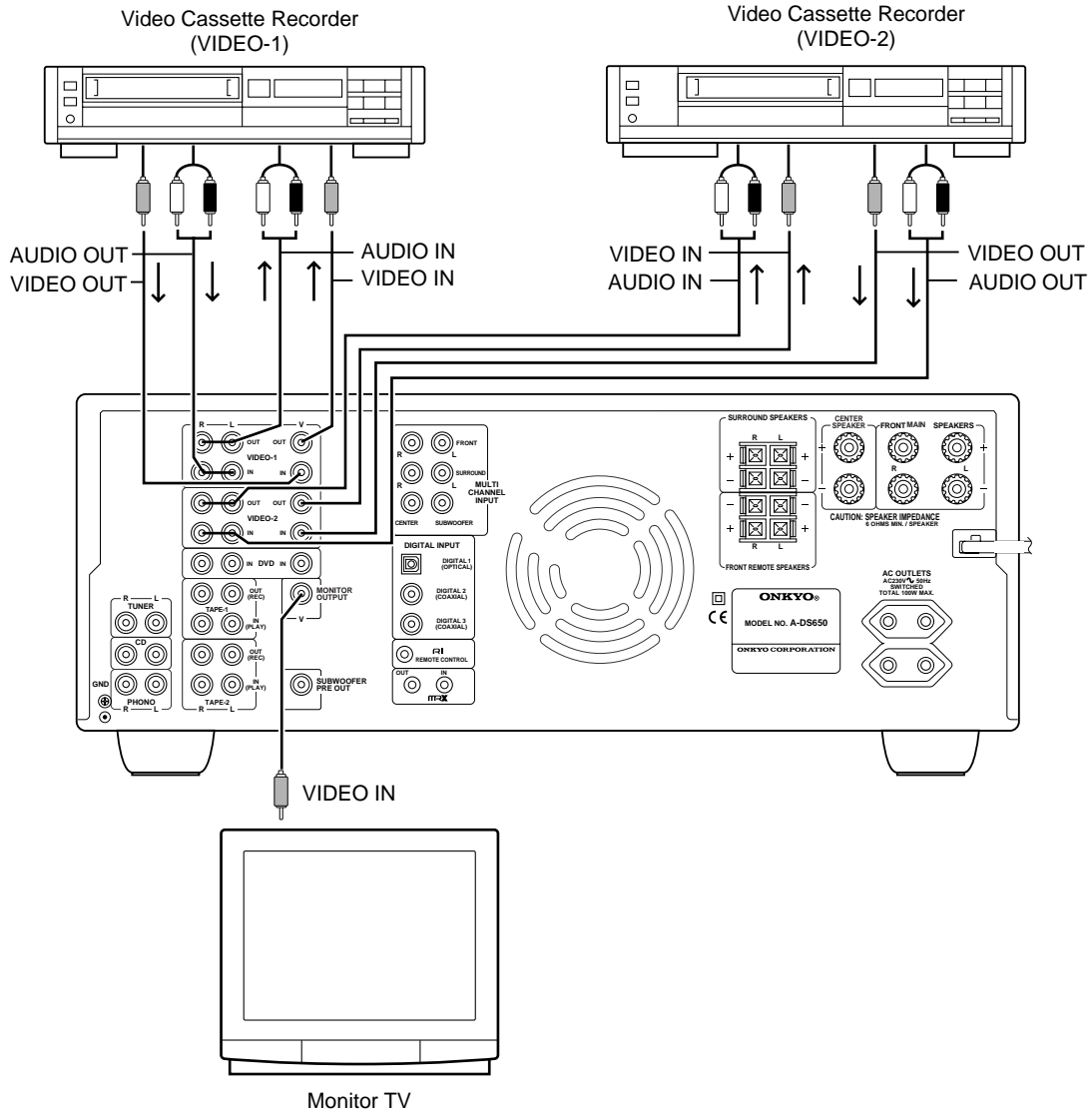

- This unit can be used only with a monitor TV equipped with a video input.
- Interference may be created between the TV and this unit. If this interference occurs, place the unit and the TV as far apart as possible.
- When using a playback-only VCR, connect its output to the A-DS650's video input connector.

Video equipment connections

IPM (Intelligent Power Management) System

The A-DS650 is equipped with an IPM system, which automatically turns on or off the amplifier's power when the TV is turned on or off. To use the IPM system, you must connect the audio output of a monitor TV to the VIDEO-2 IN connectors and press the VIDEO-2 VCR-2/TV button of the input selector. "VIDEO-2 VCR" or "VIDEO-2 TV" will appear on the display. Then, press the VIDEO-2 VCR-2/TV button again. Turn the SMART SCAN CONTROLLER to select "IPM ON" on the display. The IPM indicator will light up on the display and you will be able to use the IPM system.

The amplifier will be automatically switched on approximately five seconds after the TV is turned on and the input selector is set to "VIDEO-2". Provided that the input selector is set to "VIDEO-2", the amplifier will be automatically switched off five minutes after the TV is turned off.

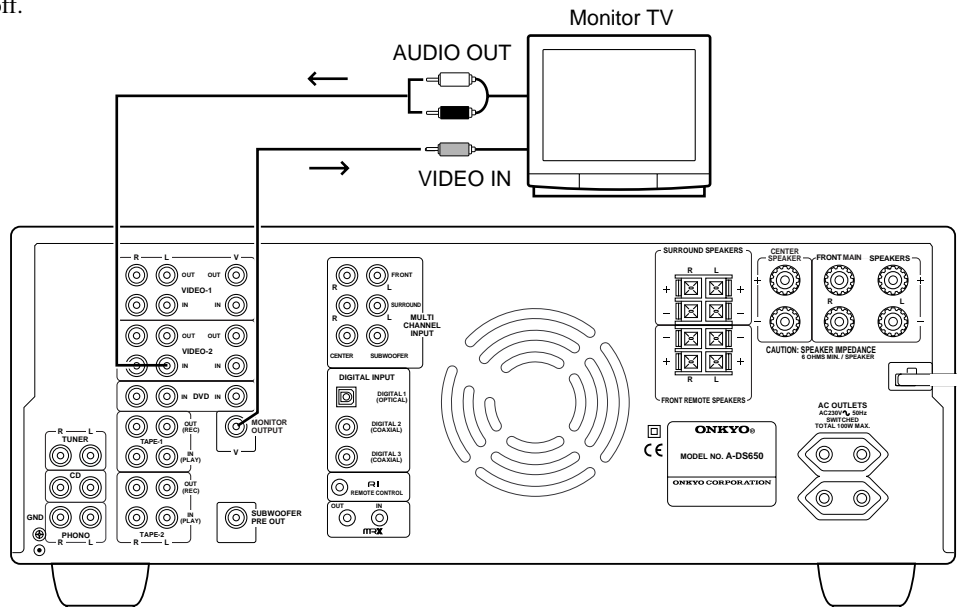

- If a mono TV is used, connect the audio output of the TV to the VIDEO-2 IN "L" connector.
- When you power off the TV, "●" flashes on the left side of the A-DS650's display, and five minutes later the A-DS650 also turns off.
- When the IPM system is set to ON, the video signal connected to the VIDEO-2 IN is not output from the MONITOR OUTPUT connector.
- If you assign the input signal from DIGITAL INPUTs to the VIDEO-2 button (see page 17), the IPM system will be automatically turned off.

Warning:

First, make sure that the IPM system works correctly with your TV before using the system.

A decoder with 5.1 channel output

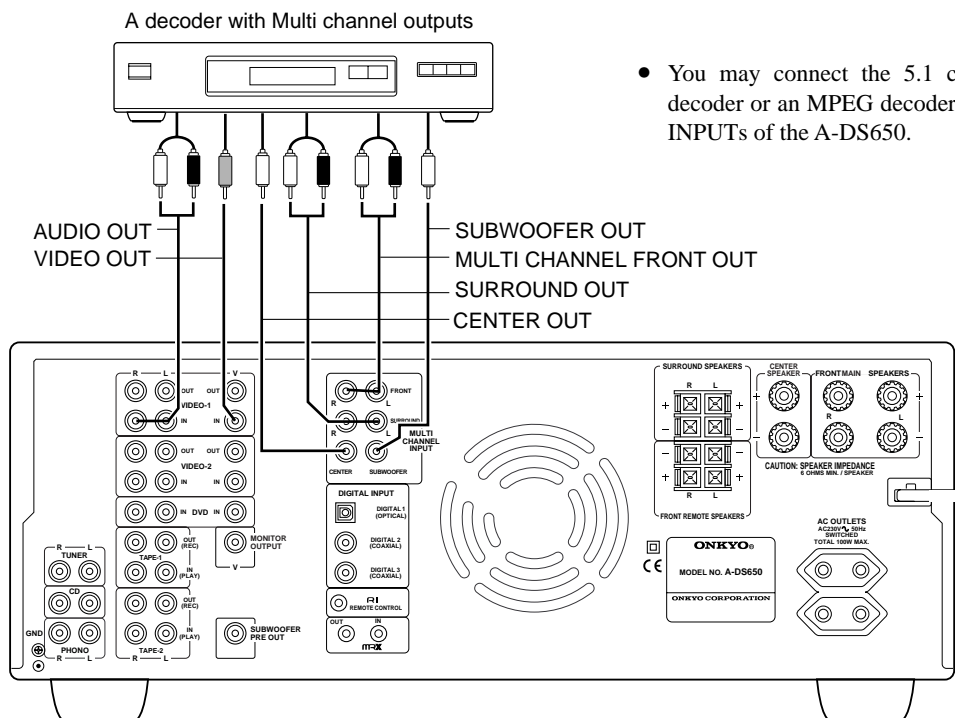

- You may connect the 5.1 channel outputs of a DTS decoder or an MPEG decoder to the MULTI CHANNEL INPUTs of the A-DS650.

Making speaker connections

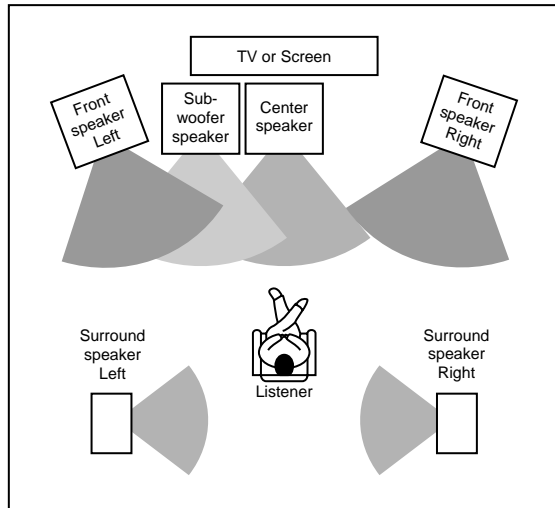

Positioning speakers

Speaker placement plays an important role in the reproduction of Surround sound. The placement of the speakers varies depending on the size of the room and the wall coverings used in the room. The illustration shows an example of a layout for standard speaker placement. Refer to this example when you position the speakers in order to experience the best of Surround sound.

Standard speaker placement

For ideal Surround effects, all speakers should be installed. If a center speaker or subwoofer is not connected, the sound from the unused channel is properly distributed to the connected speakers in order to produce the best Surround sound possible.

Front: The left, right, and center speakers should face the seated listener and be placed at ear level. The center speaker produces a richer sound image by enhancing the perception of the sound's source and movement.

Surround: Place the left and right Surround speakers 1 meter (3 feet) above the listener's ear level and toward the sides of the room, making sure that the listener is within the speakers' dispersion angle. These speakers produce the feel of a moving sound while creating the sensation of being in the middle of the action.

Subwoofer: Install a subwoofer with a built-in power amplifier for powerful bass sounds. The placement of the subwoofer does not affect the final quality of the sound image too much, so you can install it with the room layout in mind.

Refer to the speaker's instruction manual for more details.

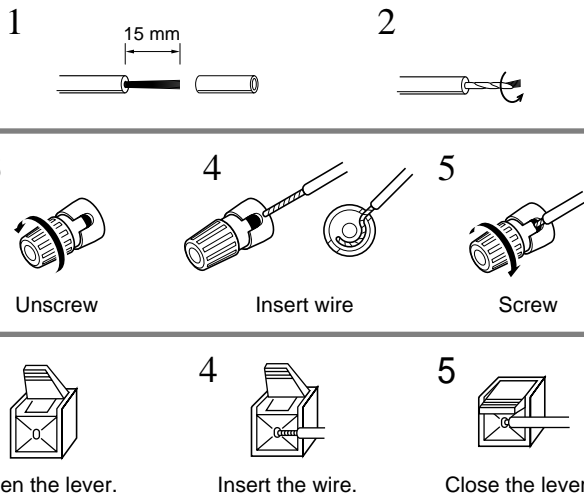

Connecting the speaker cables

When using banana plugs, make sure that you tighten the speaker terminal screws firmly before inserting the banana plugs.

- Note that the speaker terminals on European models are not banana-plug compatible.

NOTE:

To prevent damage to circuitry, never short-circuit the positive (+) and negative (-) speaker wires.

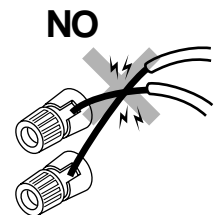

Making speaker connections

Connecting the front and surround speakers

If you want to use Surround effects, the Surround and Center speakers must be connected. (Surround effects can be heard even if a center speaker is not connected.)

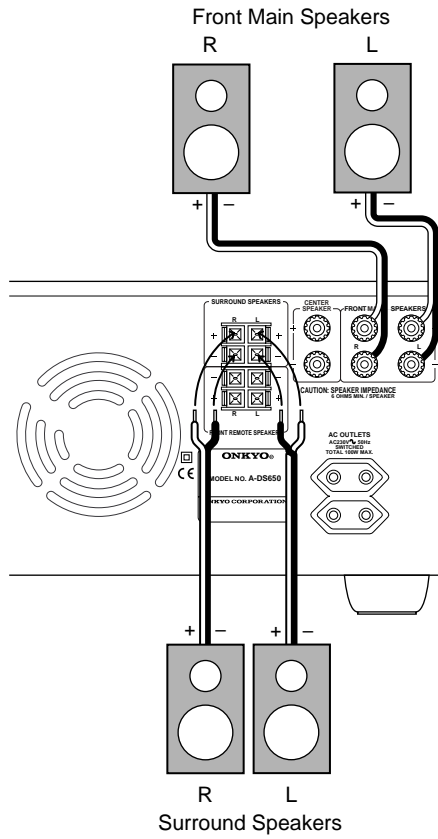

Connecting the center speaker and subwoofer

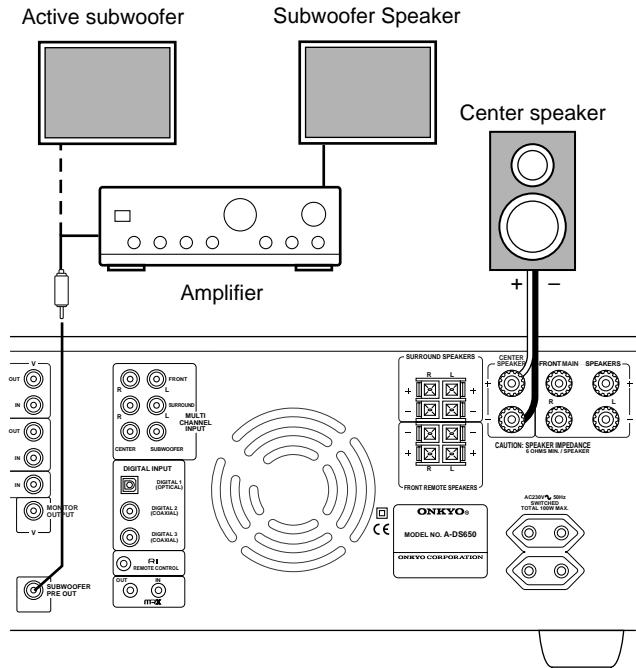

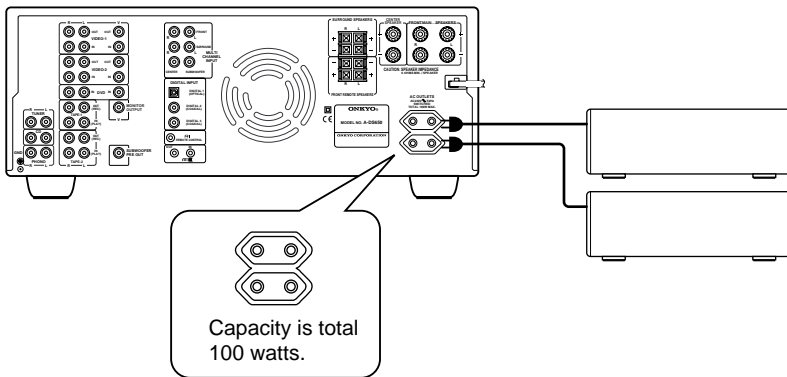

- Speaker impedance
- FRONT MAIN: 6 ohms min./speaker
- CENTER/SURROUND/FRONT REMOTE: 6 ohms min./speaker

AC outlet connections



You can connect the power cord from other audio device to the rear of the A-DS650.

Since the AC outlets on the unit are the SWITCHED type, you can use the SYSTEM button, or the POWER button on the remote controller to turn on/off the power to both the A-DS650 and the connected audio devices.

Note: If your A-DS650 has a POWER ( ON /  OFF) switch, first turn it on.

The shape, number, and total capacity of the AC outlets may differ depending on the area of purchase. Make sure that the total capacity of other components connected to this unit does not exceed the capacity that is printed on the rear panel.

Connecting the power

- Before you plug in the amplifier, confirm that all connections have been made properly.
- Before you turn on the power, make sure that the MASTER VOLUME control is fully turned counterclockwise.
- Turning on this amplifier's power may cause a momentary power surge, which might interfere with other electrical equipment, such as computers. If this happens, use a wall outlet on a different circuit.

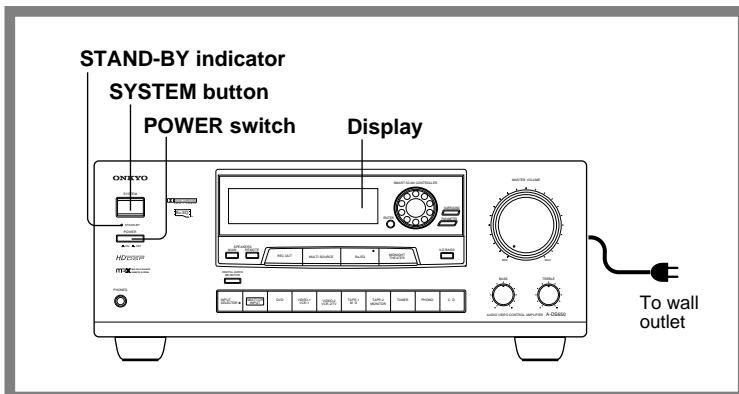

1. Plug the power cord into an AC wall outlet.
2. Press the POWER switch to set the amplifier to Standby mode.

The STAND-BY indicator will light up.

3. Press the SYSTEM button or POWER button on the remote controller to turn on the amplifier. The display will light up and the STAND-BY indicator will be turned off.

If you press the SYSTEM button or POWER button on the remote controller again, the amplifier returns to Standby mode.

- You cannot use the remote controller if the POWER switch on the amplifier is set to OFF.

Speaker system setup

1



2

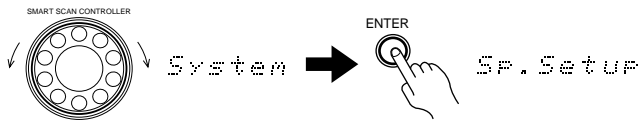

3, 4

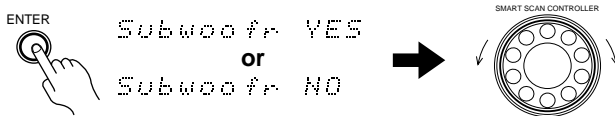

5, 6

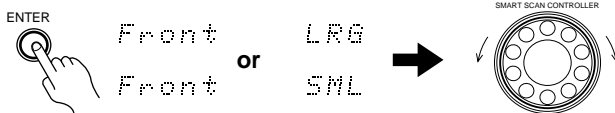

7, 8

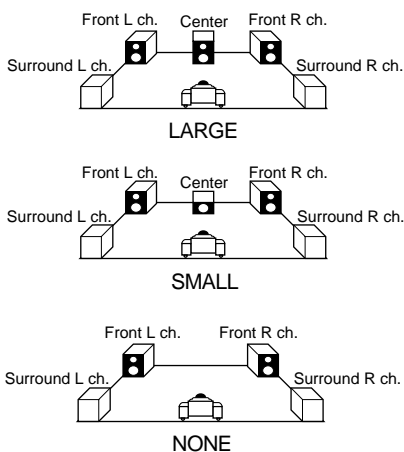
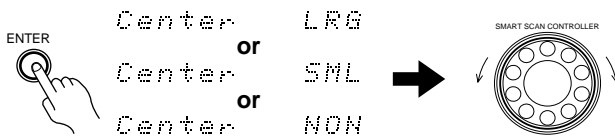

9, 10

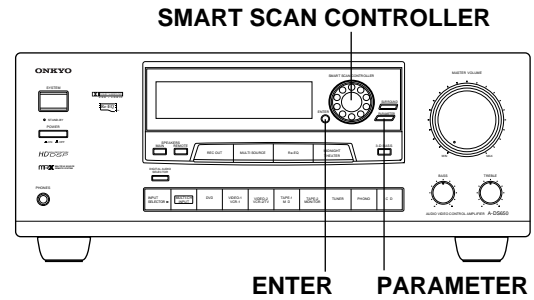
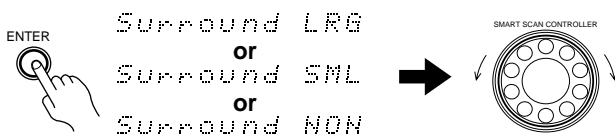

Setting up the system

You can set up the speaker system after connecting the speakers correctly (see page 11~12). Be sure to set up the system following the instructions below. Otherwise, the A-DS650 may not operate properly.

1. **Press the PARAMETER button.**
 2. **Rotate the SMART SCAN CONTROLLER to select "System Setup" and press the ENTER button.**
"Sp. Setup" appears, and you can select the type and size of the speakers as follows.
 3. **Press the ENTER button.**
You can set a subwoofer parameter. Options are "Subwoofr YES" and "Subwoofr NO".
 4. **Rotate the SMART SCAN CONTROLLER to select the desired option.**
If a subwoofer is connected to your system, select "Subwoofr YES".
 5. **Press the ENTER button.**
You can set a front speaker parameter. Options are "Front LRG (large)" and "Front SML (small)".
 6. **Rotate the SMART SCAN CONTROLLER to select the desired option.**
If you have selected "Subwoofr NO" in step 4, "Front LRG" will be selected automatically.
 7. **Press the ENTER button.**
You can set a center speaker parameter. Options are "Center LRG (large)," "Center SML (small)," and "Center NON (none)."
 8. **Rotate the SMART SCAN CONTROLLER to select the desired option.**
You cannot select "Center LRG" if you have selected "Front SML" in step 6.
 9. **Press the ENTER button.**
You can set a surround speaker parameter. Options are "Surround LRG (large)," "Surround SML (small)," and "Surround NON (none)."
 10. **Rotate the SMART SCAN CONTROLLER to select the desired option.**
You cannot select "Surround LRG" if you have selected "Front SML" in step 6.
- If the surround speaker parameter is set to "Surround NON," you may select STEREO or DOLBY 3 stereo as Surround mode. To use Surround mode, you should at least select either the center or surround speakers. Otherwise, Surround mode is disabled and the unit remains in STEREO mode.

Speaker Settings

LRG(Large): Select this for large,wideband speakers.

SML(Small): Select this for small speakers with limited bass signal handling. With this setting, the bass sounds of the speakers set to SML are re-directed to the subwoofer or other speakers set to LRG.

NON(Non): Select when center and surround speakers are not used.

Speaker system setup

12-1

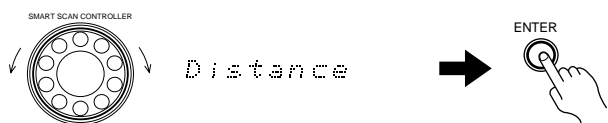

12-2

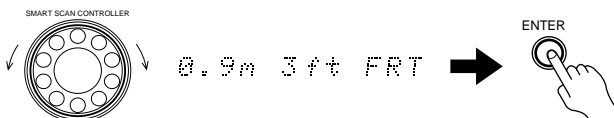

12-3

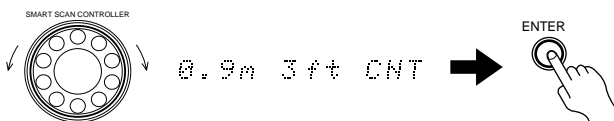

12-4

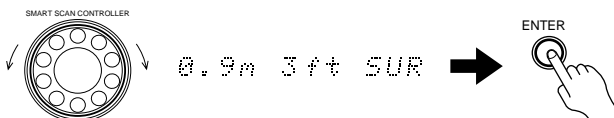

13

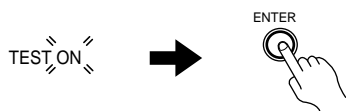

13-2

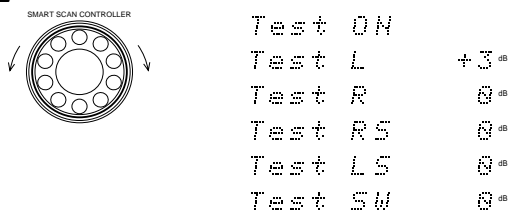

13-3

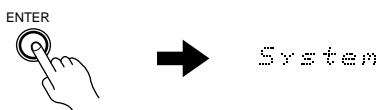

11. Press the ENTER button to confirm the setting.

12. Set the distance from the listening position to the speakers.

Select a value closest to the actual distance.

12-1. Rotate the SMART SCAN CONTROLLER to select "Distance" and press the ENTER button.

12-2. Rotate the SMART SCAN CONTROLLER to select from 0.3m 1ft FRT to 9m 30ft FRT, and press the ENTER button.

- The distance value changes in meters (0.3 m increments) or feet (1 foot increments) when you rotate the SMART SCAN CONTROLLER.
- The delay time is automatically set according to these distance values.

12-3. Rotate the SMART SCAN CONTROLLER to select from 0.3m 1ft CNT to 9m 30ft CNT, and press the ENTER button.

12-4. Rotate the SMART SCAN CONTROLLER to select from 0.3m 1ft SUR to 9m 30ft SUR, and press the ENTER button.

13. Adjust each speaker to the same relative volume level regardless of the speaker's location.

13-1. Press the ENTER button while the TEST "ON" indicator is flashing.

The test tone will sound from each speaker starting with the FRONT LEFT speaker and proceeding in the following order:

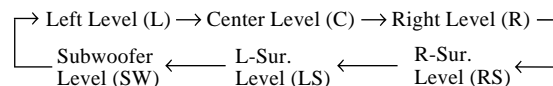

- If you have set the parameter for one of the speakers to "NO" or "NON", the corresponding speaker's test tone will not sound.

13-2. Rotate the SMART SCAN CONTROLLER to set the level (-30 dB to +12 dB for subwoofer, -12 dB to +12 dB for others) while the name of the speaker you wish to adjust appears on the display.

Repeat step 13-2 to adjust all speaker levels until the test signal level sounds the same from all speakers.

- You can also use the remote controller for this step: press the CH.SEL button to select a speaker and press the LEVEL ▲ and ▼ buttons to adjust the level.

13-3. When you finish setting the parameters, press the ENTER button.

The display will return to the System Setup indication.

- You can also press the TEST button on the remote controller to produce the test signal.

NOTE:

- The speakers do not produce sound while you are setting up the system.
- Press the PARAMETER button to cancel the system setup operation.
- If the headphones are connected, you cannot set up the speaker system.
- If the MULTI-CH INPUT is selected, use the device connected to the MULTI-CH INPUTS to set up the speaker system. For more information, refer to the instruction manual of the corresponding device.

Basic operation

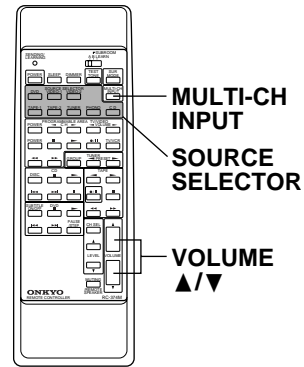
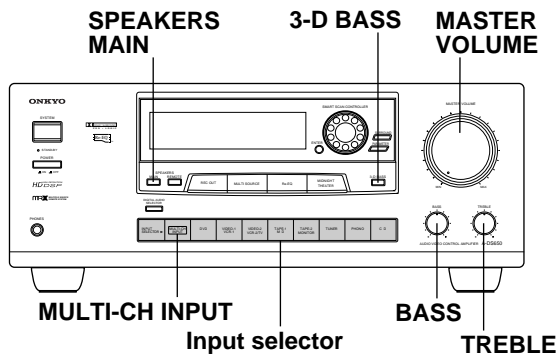

1

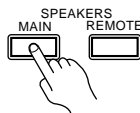

2



Remote controller

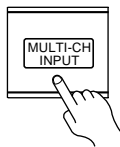
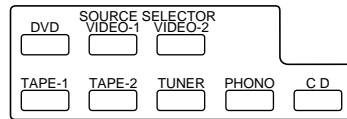

Remote controller

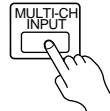

4

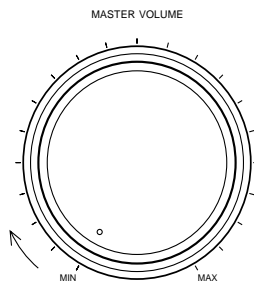

Remote controller

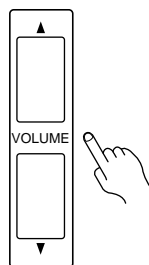

5

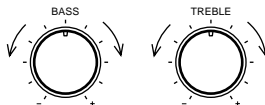
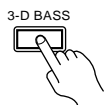

Listening to your favorite source

- 1. Press the MAIN speakers button.**
The MAIN indicator lights up.
- 2. Press the input selector button for the desired source.**
The name of the selected source will appear on the display. For FM or AM reception, the band and the frequency will also appear.
To play the selected source in Surround mode, refer to pages 20 to 23.
- 3. Start playing the selected input source.**
Follow the operating instructions for the source unit.
- 4. Adjust the volume to an appropriate level using the MASTER VOLUME knob or the VOLUME ▲/▼ buttons on the remote controller.**
- 5. Adjust the tone controls.**

NOTE:

- When you use the remote controller in the steps above, set the A/B-SUB ROOM/LEARN selector switch on the remote controller to A.
- Make sure that the MUTING indicator is not lit, and that the TAPE-2 MONITOR indicator is not lit when a source other than TAPE-2 MONITOR is selected.
- You cannot record using the MULTI-CH INPUT.
If you press the MULTI-CH INPUT while listening to a source connected to the MULTI CHANNEL INPUT, the audio input source is switched to the audio of the selected video source.

Basic operation

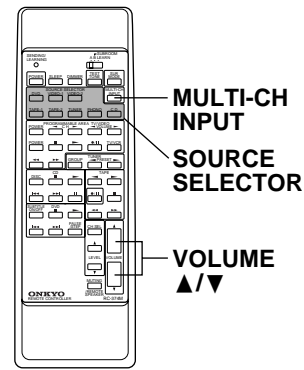
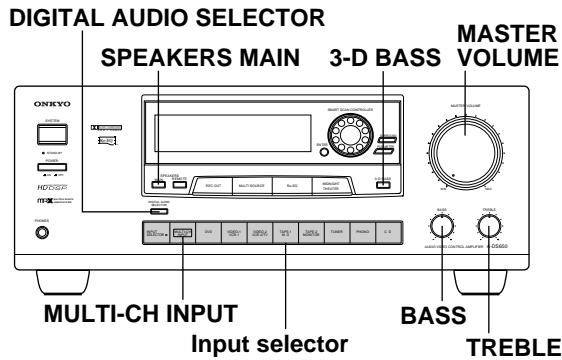

1

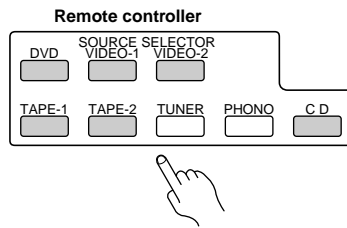

Assigning the digital inputs to input selector buttons:

1. Press an input selector button (other than the TAPE-2 MONITOR, MULTI-CH INPUT, TUNER, or PHONO button).
2. Press the DIGITAL AUDIO SELECTOR button. The current selection appears on the display. (See the illustration on the left for the options.)
3. Turn the SMART SCAN CONTROLLER until the number of the digital input appears, then press the ENTER button.
4. With the assignment complete, press the input selector button to automatically select the digital input.

2, 3

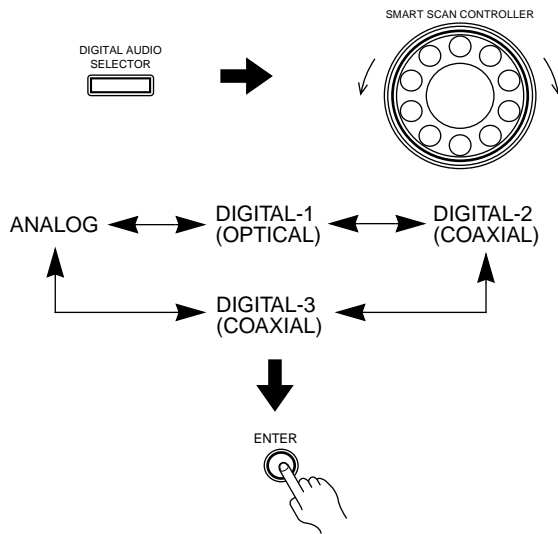

To cancel a digital input assignment, press the corresponding input selector button, then press the DIGITAL AUDIO SELECTOR button. Turn the SMART SCAN CONTROLLER to select ANALOG, then press the ENTER button.

- Even when the digital inputs are used, the analog connecting cables must be left in place. Otherwise, the multi-room remote system, TAPE OUT, and REC OUTs will not work. (See page 8.)
- When a Dolby Digital source is played, for example “3/2 ch”, appears on the display, indicating which of the three front channels and two surround channels are available for sound reproduction.

Warning:

- Do not play CD-ROM discs that contain computer data as they may cause speaker damage when amplified by the amplifier.
- The multi-room remote system, TAPE-1 and TAPE-2 REC OUTs can output signals from analog sources, but not from digital sources. If your DVD player or a component equipped with digital output has both analog and digital outputs, connect both of them so that you can listen to and record both signals at the same time.

Listening with headphones

You can connect stereo headphones to the PHONES jack using a standard stereo plug.

If you connect headphones, the unit will enter STEREO mode will be entered automatically, and no sound will be produced from the speakers. If you have selected MULTI-CH INPUT, you will hear only the audio from FRONT L and R of MULTI-CH INPUT.

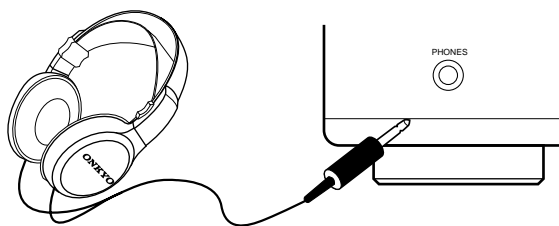

Basic operation

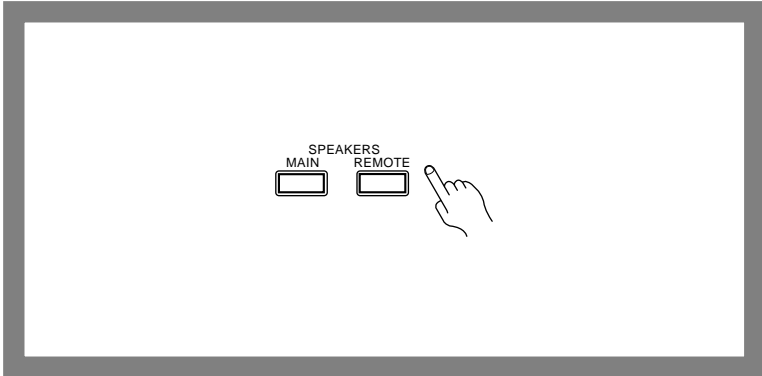
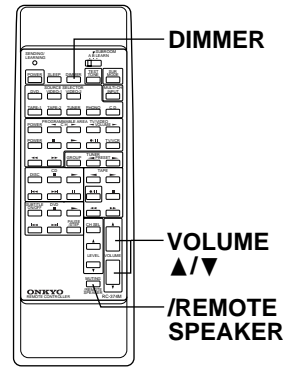
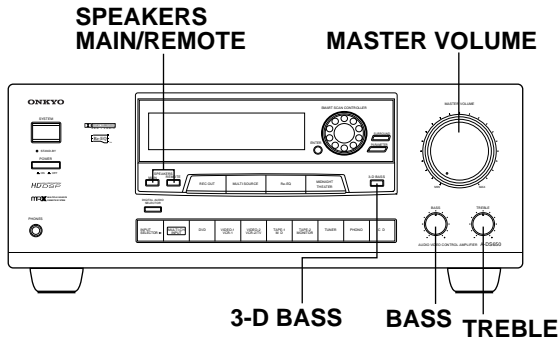

SPEAKERS selector

MAIN: This button turns on or off the speakers connected to the FRONT MAIN SPEAKERS, CENTER SPEAKER, SURROUND SPEAKERS, and SUBWOOFER terminals. When the speakers are turned on, the MAIN indicator lights up.

REMOTE: This button turns on or off the speakers connected to the FRONT REMOTE SPEAKERS terminals. When the speakers are turned on, the REMOTE indicator lights up. Turn on these speakers when using multiple sources. (See page 29.)

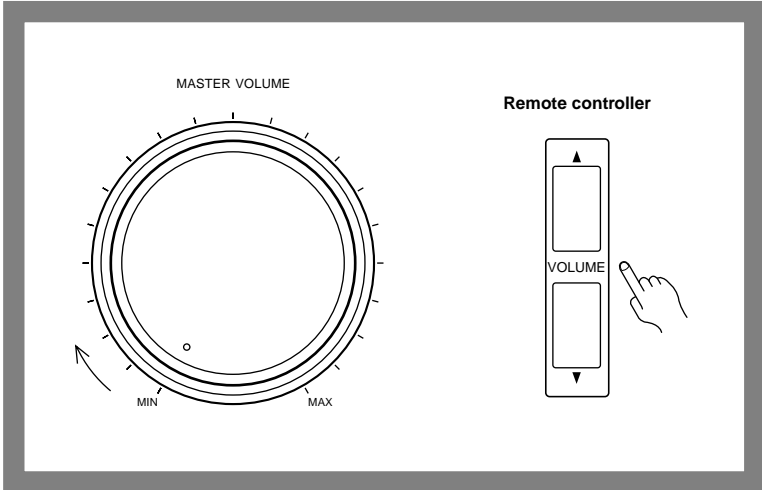

MASTER VOLUME control

The MASTER VOLUME control knob adjusts the volume of the front, center, surround and subwoofer speakers simultaneously. Turning it clockwise increases the volume. You can also adjust the volume using the remote controller's VOLUME ▲/▼ buttons.

The Master Volume level settings are: $-\infty$ dB (minimum), $-58 \sim -1$, 0 , $+1 \sim +18$ dB (maximum).

Depending on the calibration, it may be impossible to set the Master Volume level to +18dB. Even if the knob is manually turned to its maximum, it will return to its highest possible setting.

The MASTER VOLUME control does not affect the MULTI SOURCE Level. Use the remote controller to adjust the multi-source level.

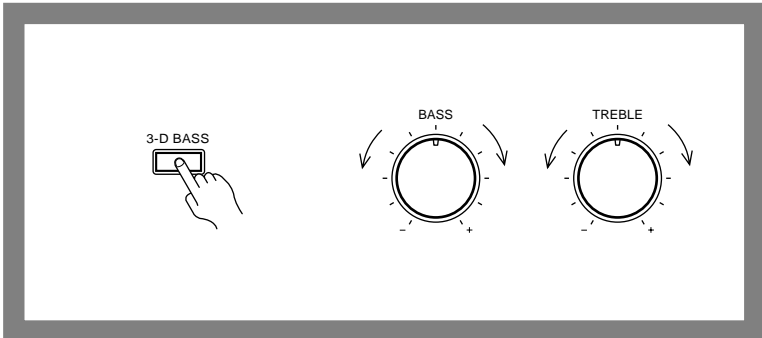

Adjusting the tone

BASS: Adjust to strengthen or weaken bass response.

TREBLE: Adjust to strengthen or weaken treble response.

3-D BASS: This button is used to clearly reproduce ultra low frequencies. When this button is pressed, the 3-DB indicator lights up. 3-D BASS can be used in all surround modes.

- The 3-D BASS control affects only the left/right Front and Center speakers. The BASS and TREBLE controls affect only the left/right Front speakers.

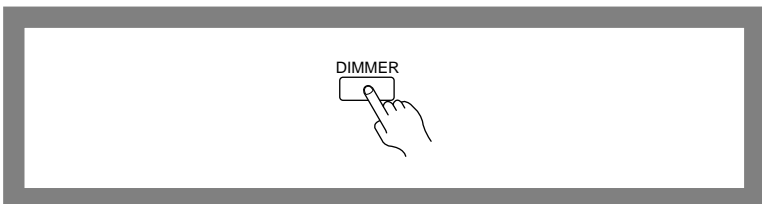

DIMMER button (Remote controller only)

Use this button to change the brightness of the display. The brightness changes to bright, normal, or low.

Basic operation

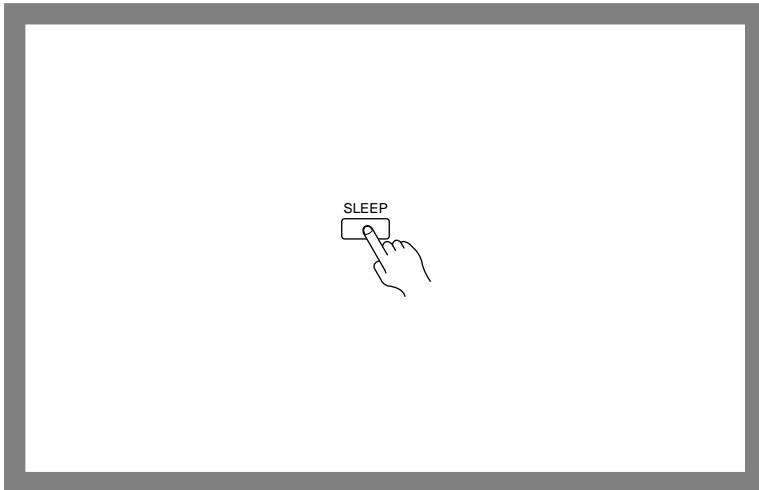
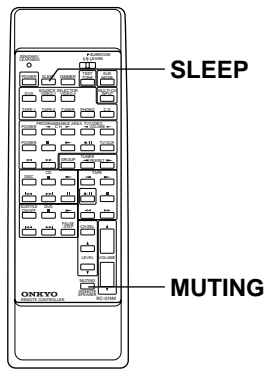

Sleep timer function (Remote controller only)

Press to set the power-off timer. The sleep timer is a function that turns off the power to the system after a certain period of time. When this button is pressed, "90 MIN" is displayed for five seconds, and the power will go off 90 minutes later. Each time the button is pressed within five seconds, the timer setting changes in 10 minutes increments (e.g. 80, 70, 60 ...). While the sleep timer is operating, the SLEEP indicator is lit. If you press the sleep button during this time, the amount of time remaining on the timer is displayed, and if you press the button during that display, 10 minutes will be subtracted from that time.

If you press the button when the panel display indicates 10 minutes or less, the sleep timer will be cancelled, and the power will not be turned off.

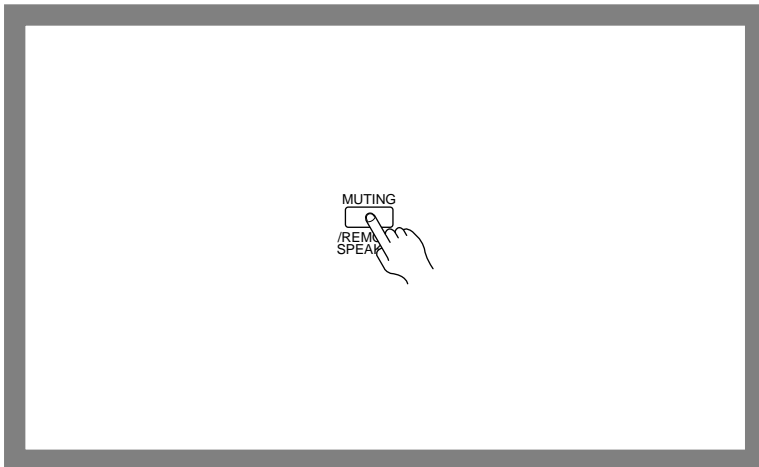

Muting the sound (Remote controller only)

This button temporarily switches off the sound from the speakers or headphones by operating this unit's audio muting circuits. The MUTING indicator will flash. Pressing the button again or using the POWER button on the remote control to turn the power on will turn off the audio muting. Audio muting using this button does not affect the sound of the multi-source (Remote speakers).

Press the SPEAKERS REMOTE to mute the sound of the multi-source.

Using Surround mode

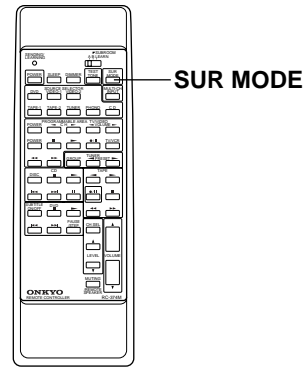
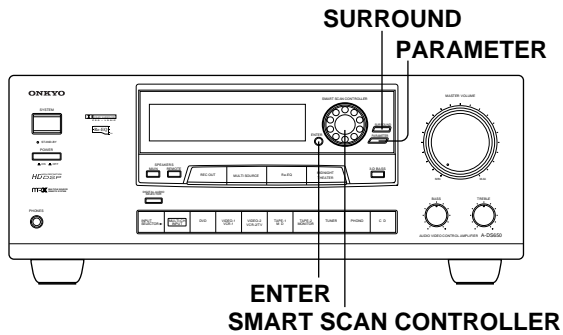

1

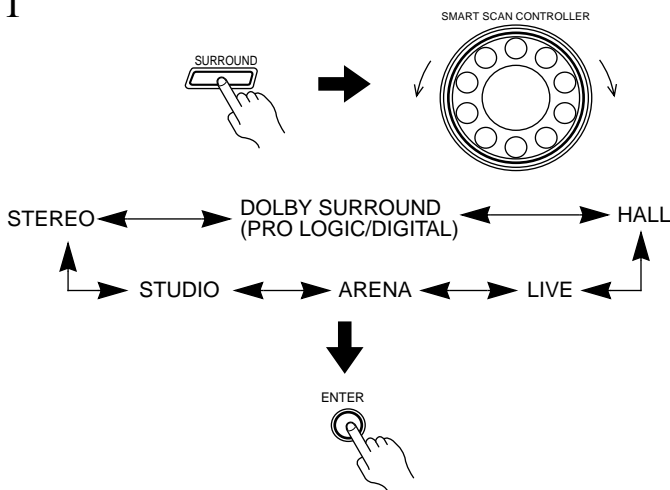

2

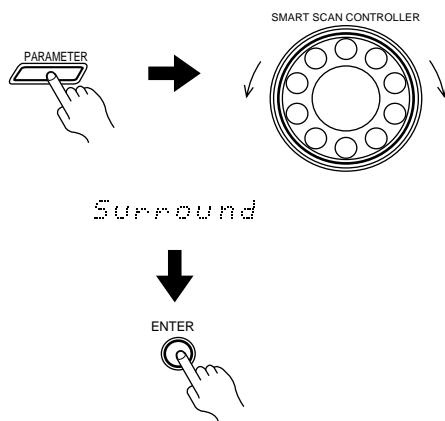

3

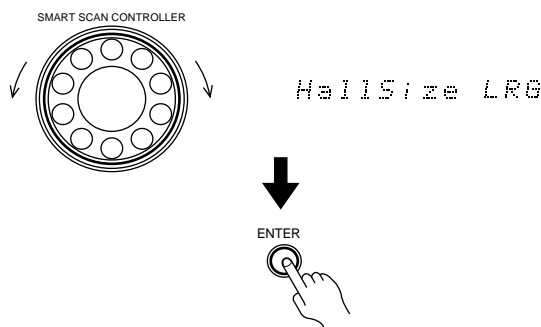

Selecting a Surround mode

Before using a Surround mode, make sure the System Setup parameters have been set. If the parameters have been set once, it is not necessary to set them again.

Dolby Digital Surround mode is used to decode media such as DVD discs bearing the mark and Dolby Digital broadcasts. With Dolby Surround mode, video tapes and laser discs bearing the trademark are decoded to reproduce the multi-channel Surround sound of a movie theater.

1. Press the SURROUND button.

Rotate the SMART SCAN CONTROLLER toward the right or left to select the desired Surround mode. Surround mode names appear sequentially.

- If you are using the remote controller, press the SUR. MODE button to select the desired Surround mode. If DOLBY PRO LOGIC is selected during playback of a DOLBY DIGITAL source, the Surround mode automatically changes to DOLBY DIGITAL and DOLBY DIGITAL indicator lights up on the display.

In addition, an indication such as “3/2 ch”, appears in the main unit’s multi-function display to indicate which of the three front channels and two Surround channels are available for sound output.

Each mode has a number of parameters that can be used to adjust the sound. (Refer to page 21~22 for more details.)

2. Press the PARAMETER button.

Rotate the SMART SCAN CONTROLLER to the left until “Surround Setup” appears on the display.

3. Press the ENTER button repeatedly to select the desired parameter, then use the SMART SCAN CONTROLLER to select the appropriate settings.

- Refer to the Parameter chart on page 21 for the order in which the parameters appear.
- The parameter name appears on the display for five seconds. If it disappears, repeat step 2.

4. Repeat step 3 to adjust the parameters.

- HALL, LIVE, ARENA, and STUDIO modes are not available during playback in DOLBY DIGITAL Surround mode.

Using Surround mode

A-DS650 Parameters

This chart shows how the display changes when you press the ENTER button. Rotating the SMART SCAN CONTROLLER clockwise or counterclockwise in each display can change the value and condition of whichever parameter is displayed.

The following parameters appear in the multi-function display on the front panel when the PARAMETER button is turned ON.

System Setup

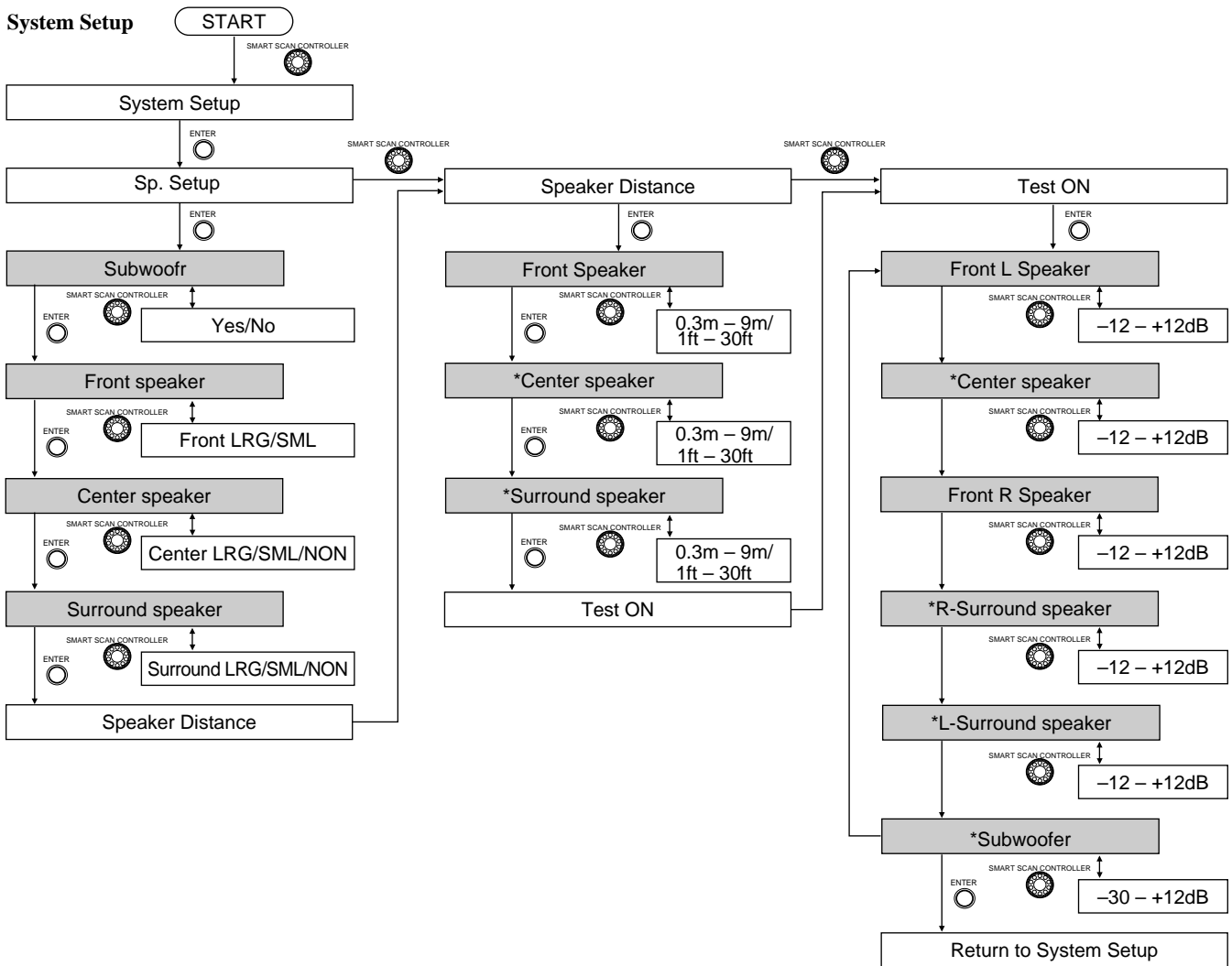

* Indicates parameters that are skipped when the corresponding Center Speaker, Surround Speaker, and Subwoofer parameters are set to NONE or NO.

Surround Setup

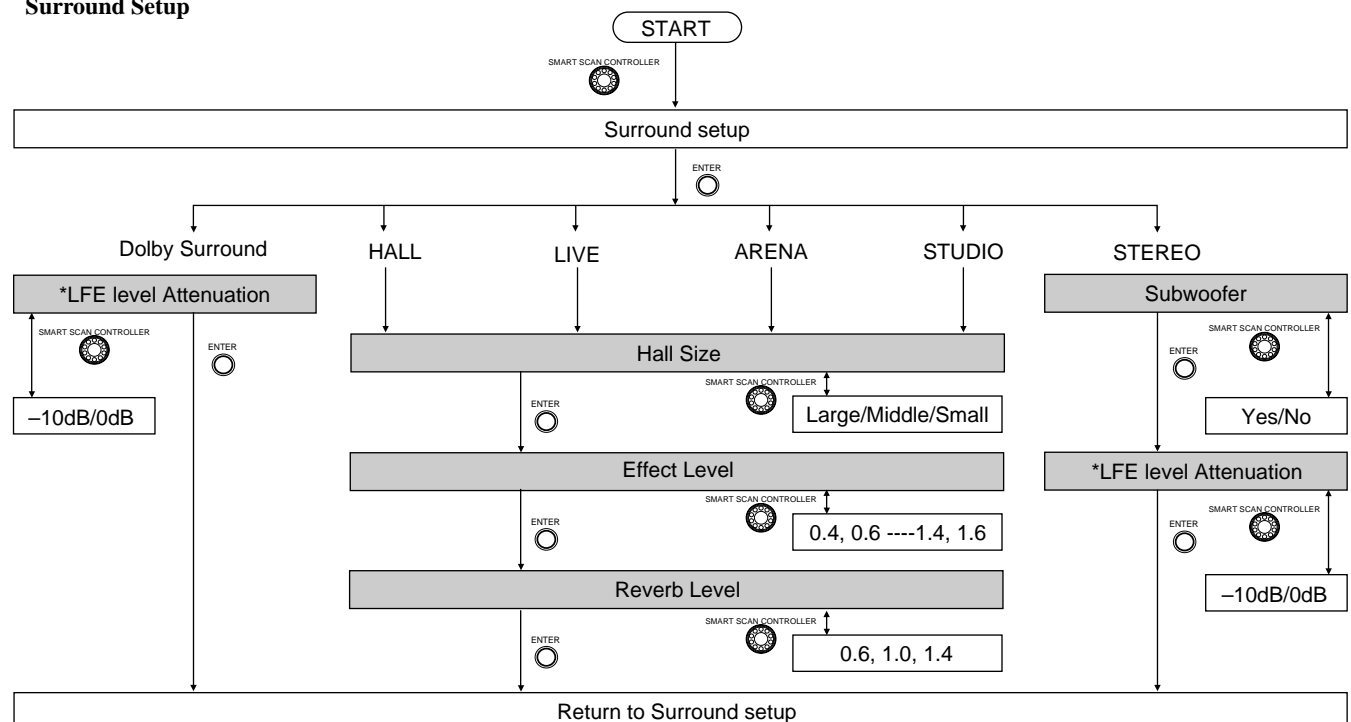

* Indicates a parameter that appears only with the Dolby Digital Surround mode. With the Dolby Pro Logic Surround mode, this parameter is skipped.

Using Surround mode

Setting the Surround mode parameters

LFE (Low Frequency Effect) Level Attenuation

If the reproduced bass is too loud, set this parameter to “-10 dB” to decrease the Low Frequency Effect in the low-frequency channel by 10 dB.

- The LFE Level Attenuation function is available only in Dolby Digital Surround mode.

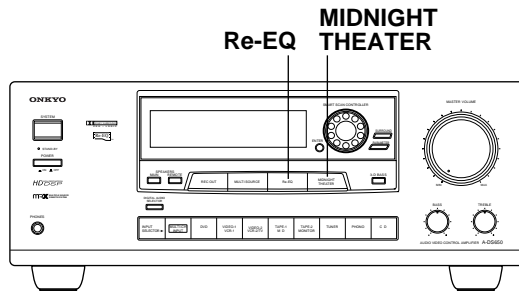

Cinema Re-Equalization

Re-Equalization takes the edginess or “brightness” out of your home cinema sound, compensating for the fact that sound mixed for theaters will sound too bright when played back through speakers in the home environment.

Press the Re-EQ button, the Cinema Re-Equalizer indicator appears on the display. To cancel the Re-EQ function, press the Re-EQ button again.

- The Cinema Re-EQ function is available only in Dolby Digital and Dolby Pro Logic Surround and Multi channel input modes.

Midnight Theater

If you play a movie at a low volume at night, set this parameter to “ON” to narrow the dynamic range of the reproduced sound to make it easier to hear.

The Midnight Theater function works only with source material that contains the necessary Dolby Digital information.

Press the MIDNIGHT THEATER button, the MIDNIGHT THEATER indicator appears on the display. To cancel the MIDNIGHT THEATER function, press the MIDNIGHT THEATER button again.

- The Midnight Theater function is available only in Dolby Digital Surround mode.

Hall size

These parameters allow you to set the size of the hall/live/arena/studio. The size can be selected from three settings, ranging from LRG/MID/SML.

Effect Level and Reverb Level

By adjusting the level of the early reflections and reverberation of sounds for a recording, it is possible to create the illusion of actually being in a hall without leaving your living room.

Effect Level: Adjusts the early reflection level. Raising the setting increases the effect sound level. You can select from seven settings between 0.4 and 1.6.

Reverb Level: Adjusts the level of only the reverb (not the early reflections). Raising the setting increases the reverb sound level. You can select from three settings between 0.6 and 1.4.

Using Surround mode

STEREO parameters

1. Select the STEREO parameter.
2. Indicate whether or not you are using a subwoofer.
If you have set the System Setup's Subwoofer parameter to YES, you can still specify whether or not you wish to use the subwoofer when Surround mode is STEREO. Set this parameter to YES if you wish to use the subwoofer in STEREO mode. If you have set the System Setup's Subwoofer parameter to NO, this parameter will not appear.

When Multi channel input is selected as a source

1. Select Multi-channel input as an Input selector.
You cannot select any Surround mode.
2. Adjust the speaker volume.
You can adjust the volume level of each speaker individually. Adjust them while listening to the sound from the listening position.
Using the remote controller:
 - ① Press the CH-SEL button to select the desired speakers.
 - ② Use the LEVEL ▲/▼ button to change the volume level of the speaker.

Using the front panel of the unit:

You can adjust the level for the left speaker, center speaker, right speaker, right surround speaker, left surround speaker, and subwoofer, in this order.

The following illustration shows the relationship between the parameters and the PARAMETER, ENTER buttons, and SMART SCAN CONTROLLER.

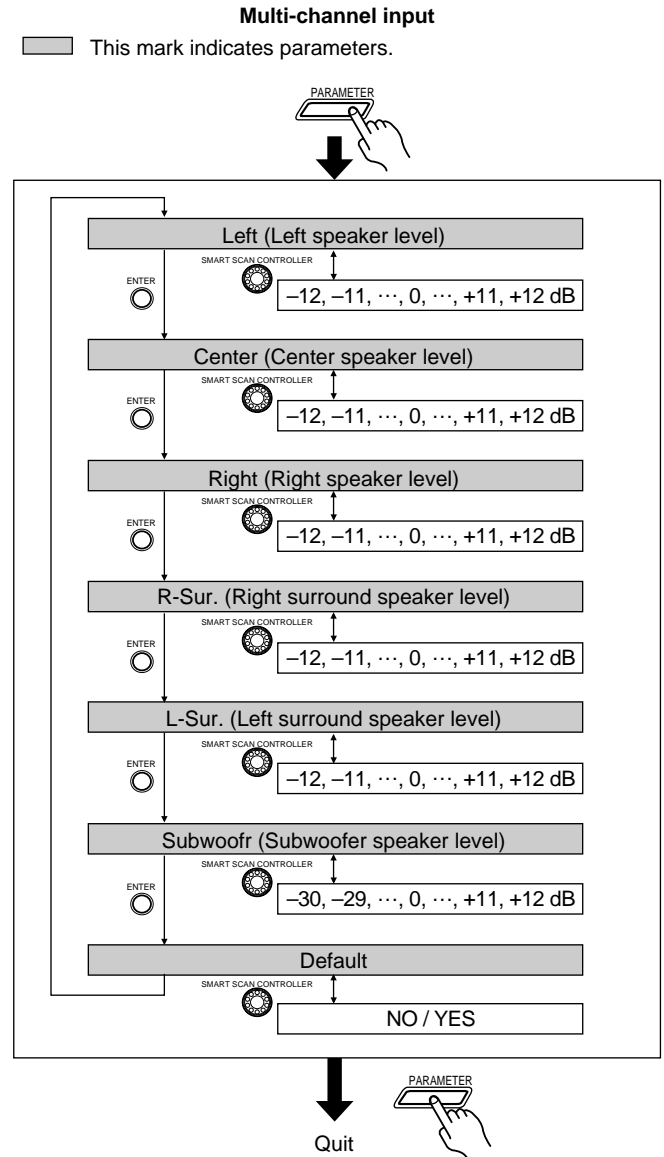

Recording a source

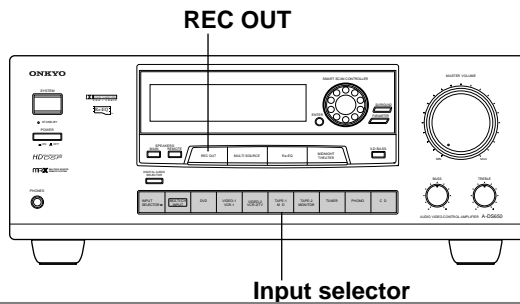

1



2

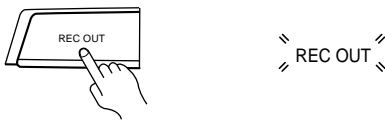

3



1

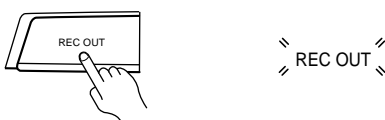

2

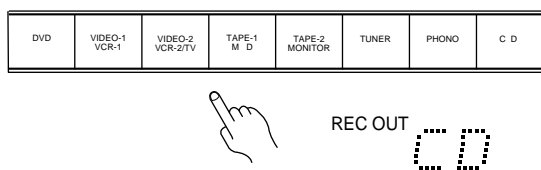

1

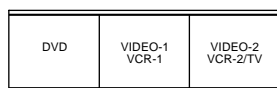

3



4



You can use the A-DS650 to record either the source you are currently listening to or watching, or a different source. Check that the components are connected to the A-DS650 as shown in "Audio equipment connections" and "Video equipment connections" on pages 7 and 10.

NOTE:

Digital audio cannot be routed to the recording output.

Listening to or watching a source while recording it

1. Press an input selector button to select the desired source.
2. Press the REC OUT button. The REC OUT indicator will flash for eight seconds.
3. Press the REC OUT button again while the REC OUT indicator is flashing. The "S" (source) will be shown in the right corner of the display.
4. Start recording on the recording component, then start playing the selected source.

NOTE:

- If you have selected MULTI-CH INPUT in Step 1, the REC OUT connector will output the audio signals of the selected video input.
- Do not adjust any controls on the A-DS650 after starting the recording operation.
- Pressing an input selector button while recording will change the source being recorded.
- When the TAPE-2 MONITOR indicator is lit, only the TAPE-2 source can be recorded. Even if a different input selector button is pressed, the TAPE-2 MONITOR indicator will remain lit.

Listening to or watching a source while recording to another

1. While listening to or watching a source, press the REC OUT button.
2. Press an input selector button (other than MULTI-CH INPUT) for the source to be recorded, while the REC OUT indicator is flashing. (e.g., CD)
 - The abbreviation for the selected source name appears on the source display. VIDEO-1 (V1), VIDEO-2 (V2), DVD (D), TAPE-1 (T1), TAPE-2 (T2), TUNER (TU), PHONO (PH), CD (CD)
 - At this time, pressing the MULTI-CH INPUT will change the current source to MULTI-CH INPUT.
3. Start recording on the tape deck or VCR, and start the source selected in step 2.

Mixing video and audio for VCR recording

1. To record different video and audio sources to a destination VCR, first, select the video source using the input selector buttons.
2. Press the REC/PAUSE button on the destination VCR.
3. Press the REC OUT button. The REC OUT indicators flashes for eight seconds.
4. While the REC OUT indicator is flashing, select the audio source using the input selector buttons (other than MULTI-CH INPUT). The selected music source is indicated on the display. For example, "CD".
5. Start recording on the destination VCR, and then start playback on the video and audio sources. The video and audio sources are recorded by the destination VCR.

Using TAPE-2 MONITOR

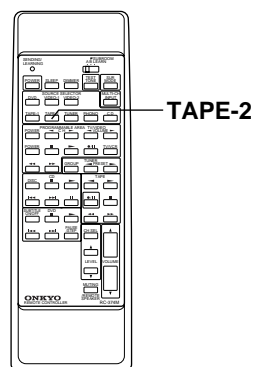
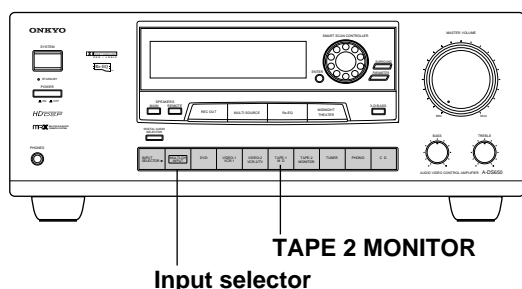

1

Remote controller

TAPE-2 MONITOR

Playing back using TAPE-2 MONITOR

Using the amplifier or remote controller:

1. Press the **TAPE-2 MONITOR** (or **TAPE-2**) button.
The TAPE-2 MONITOR indicator lights up on the display.
 2. Follow the operating instructions for the TAPE-2 tape deck to start playback.
- If you have selected the MULTI-CHANNEL INPUT, turning TAPE-2 MONITOR on will automatically select the audio signal of the selected video input as an input.
 - If you are not using the component connected to the TAPE-2 connectors, make sure that the TAPE-2 MONITOR indicator is off. Otherwise you won't be able to listen to other sources.

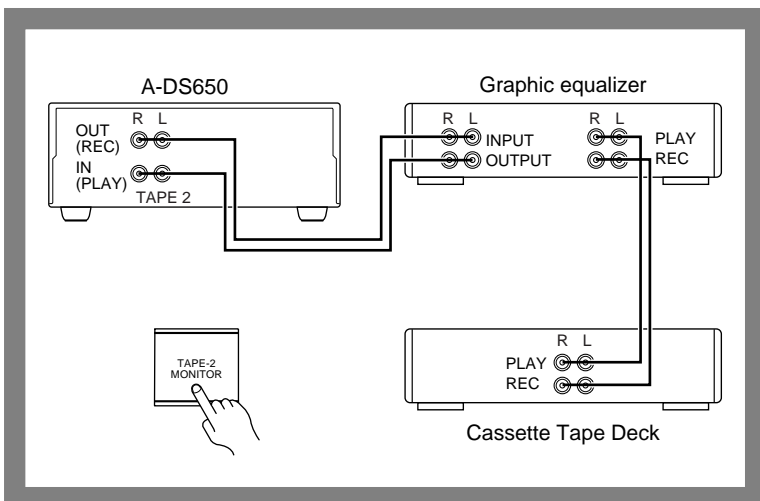

Using a graphic equalizer

1. Connect the graphic equalizer to the TAPE-2 connectors on the rear panel of the A-DS650.
2. If a second tape deck is used, connect it to the tape deck connectors on the graphic equalizer.
3. Press the **TAPE-2 MONITOR** button.
The TAPE-2 MONITOR indicator lights up on the display.
4. Follow the operating instructions for the graphic equalizer.
To record an equalized signal, use the tape deck connected to the equalizer.

CAUTION:

- Do not select a Surround mode when using the equalizer. Otherwise, it will result in distortion and possible damage to the Surround decoder circuitry.

1

DVD	VIDEO-1 VCR-1	VIDEO-2 VCR-2/TV	TAPE-1 M D	TAPE-2 MONITOR	TUNER	PHONO	C D
-----	------------------	---------------------	---------------	---------------------------	-------	-------	-----

Recording using TAPE-2 MONITOR

Using the amplifier:

1. Press an input selector button to select the source to be recorded.
 2. Start recording using the TAPE-2 tape deck, then start playing the selected source.
Refer to the tape deck owner's manual for more details.
- If the TAPE-2 MONITOR indicator in the display is not lit, you will hear the sound from the source.
 - If a 3-head tape deck connected to the TAPE-2 connectors is used for recording, press the TAPE-2 MONITOR button to turn on the TAPE-2 MONITOR indicator and listen to the sound that was just recorded.
 - Set the recording level with the controls on the recording tape deck.

Programming remote controller codes

Universal Programmable Remote Controller RC-374M

If you are using another manufacturer's product that has a remote controller, you can memorize that component's codes into the RC-374M.

NOTE:

- The commands of Onkyo cassette tape decks and the CD player are already stored at the TAPE and CD positions of the remote controller.
- This remote controller uses infrared rays. Most remote controller codes can be memorized using the infrared system; however, depending on the degree to which the system differs, there may be some rare occasions when memorization is not possible.

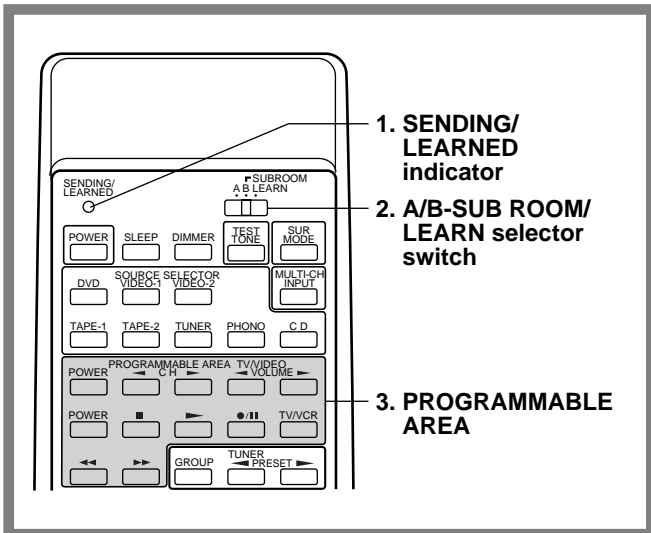

Displays and switches

1. SENDING/LEARNED indicator

This indicator acts as a guide when commands are programmed into or sent by the remote controller. It also warns the user when an error is made or battery power is low.

2. A/B-SUB ROOM/LEARN selector switch

A: Select MAIN to operate the system from the main room, such as when playing a sound source using a Surround mode.

B-SUBROOM: Select SUB to operate the Onkyo Multi-Room Remote System, the A-DS650, and other brands' components from the sub-room.

LEARN: Select LEARN to store another remote controller's signal code.

3. Programmable button area

See the table below.

Symbol	Device commands		
	VDP	VCR	TV
POWER	POWER	POWER	POWER
▶	PLAY	PLAY	–
■	STOP	STOP	–
◀ C H ▶	–	–	CHANNEL UP, DOWN
◀◀	–	FAST REWIND	–
▶▶	–	FAST FORWARD	–
◀ VOLUME ▶	–	–	VOLUME UP/DOWN
●/	–	Rec/Pause	–
TV/VCR	–	–	TV/VCR switching

Programming remote controller codes

1

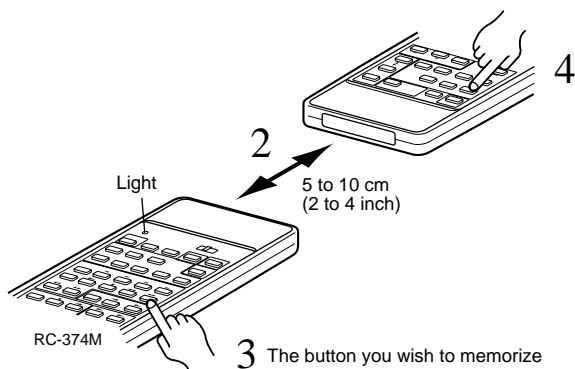
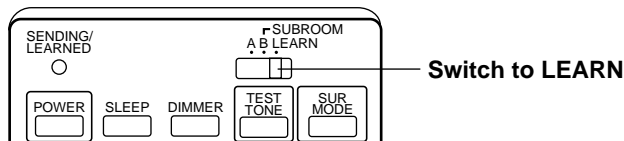

Learning new controller codes

1. Set the A/B-SUB ROOM/LEARN selector switch to **LEARN**.
2. Place the head of your old remote controller 2-4 inches (5-10 cm) from the head of the RC-374M, laying both units on a table or a flat surface.
3. On the RC-374M, press the button in the **PROGRAMMABLE AREA** into which you want to store the code.
 - The **SENDING/LEARNED** indicator lights up.
4. On your old remote controller, hold down the button for the function you want the RC-374M to memorize while the **LEARNED** indicator is lit. Keep pressing this button until it turns off.
 - To store a code to another button, repeat steps 3-4.

NOTES:

- Some remote controllers use a single button to perform different functions, with the function code changing each time the button is pressed. If you are using this kind of controller, please perform the “learn” operations for each function individually to store each function to a button on the RC-374M.
- For instructions regarding the operation of “learned” units, please refer to the instruction manual for each product.
- Even after codes have been memorized, please keep your old remote controller in a safe place. If the memorized codes are lost when the batteries run down, it will be necessary to memorize them once again using the old remote controller.

Reprogramming the buttons:

Follow the steps 1-4 described above. The previous codes will be lost, and new codes will be stored.

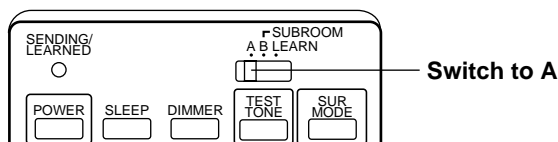

Operating the RC-374M

Please check whether previously-memorized functions are working properly. If the **SENDING** indicator is not illuminated when a programmed button is pressed, it may need to be released from your old remote controller.

Set the A/B-SUB ROOM/LEARN selector switch to the A position.

Then operate the remote controller by pressing the buttons of the functions you want to use.

- If you press a button that has no code stored, the **SENDING/LEARNED** indicator will not light up.

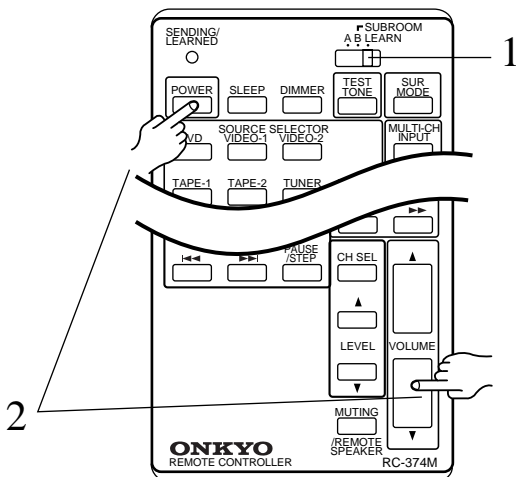

Clearing all memorized codes

1. Set the A/B-SUB ROOM/LEARN selector switch to **LEARN**.
2. Press and hold the **POWER** and **VOLUME ▼** buttons together until the **SENDING/LEARNED** indicator turns off.
 - All codes stored in the programmable area will be deleted.

Connection for multiple-room remote control

Do not plug in the power cord until all connections have been made.

Make connections as shown in the Connection Diagram below. Make sure all components are correctly connected.

■ Connecting components equipped with Onkyo **RI** connectors

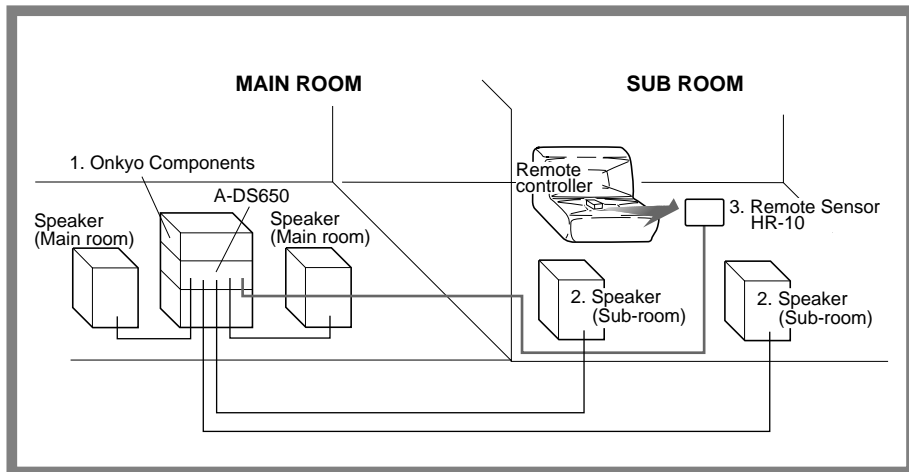

1. Set up the Onkyo **RI** components.
2. Connect the sub-room speaker cables to the FRONT REMOTE SPEAKERS terminals on the A-DS650.
3. Install Remote Sensor HR-10 in the sub-room, then connect it to the A-DS650.

■ Connecting components not equipped with Onkyo **RI** connectors

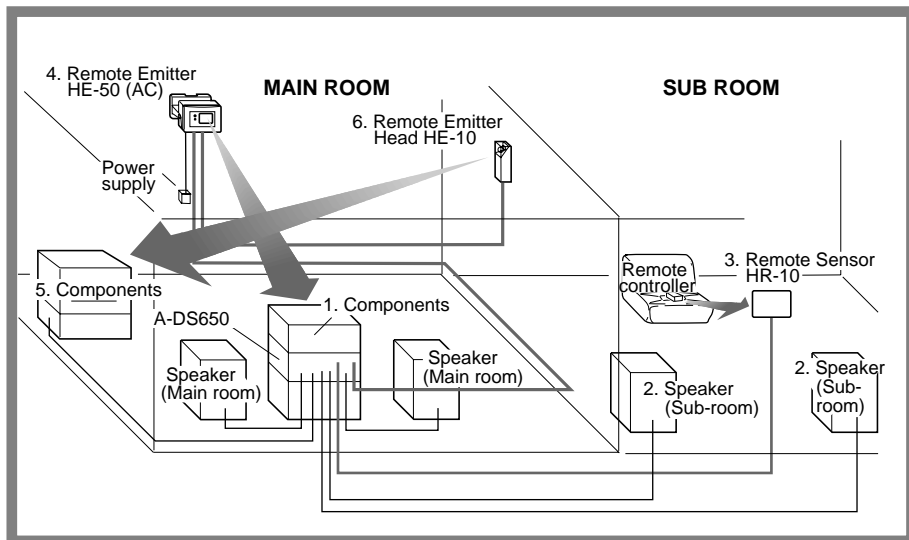

1. Connect the components to the A-DS650.
Make the connections described above in steps 2 through 3.
4. Install the Remote Emitter HE-50 (AC) so that its sensor is directed toward these components, then connect it to the A-DS650.
(Connect the AC adapter to the Remote Emitter.)

To operate components positioned out of range of the emitter:

5. Connect these components to the A-DS650.
6. Install Remote Emitter Head HE-10 so that its sensor is directed toward these components, then connect it to the HE-50 (AC).

Connecting diagram

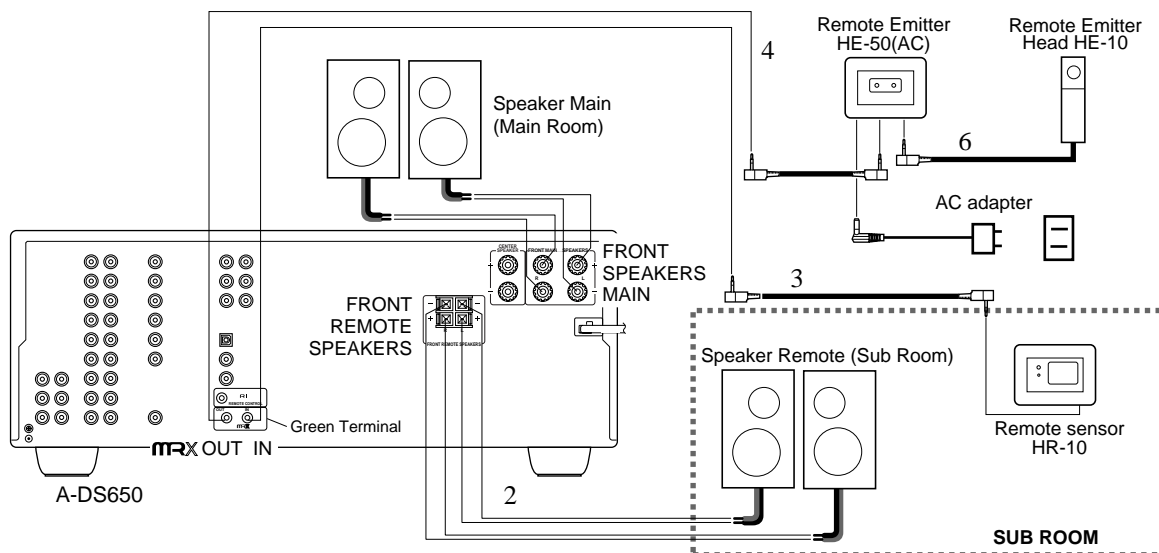

Listening in another room

Make sure that recording is not being carried out before performing the following operations.

Please refer to page 28 for connection details.

On the RC-374M remote controller, first set the A/B-SUBROOM/LEARN switch to B-SUBROOM.

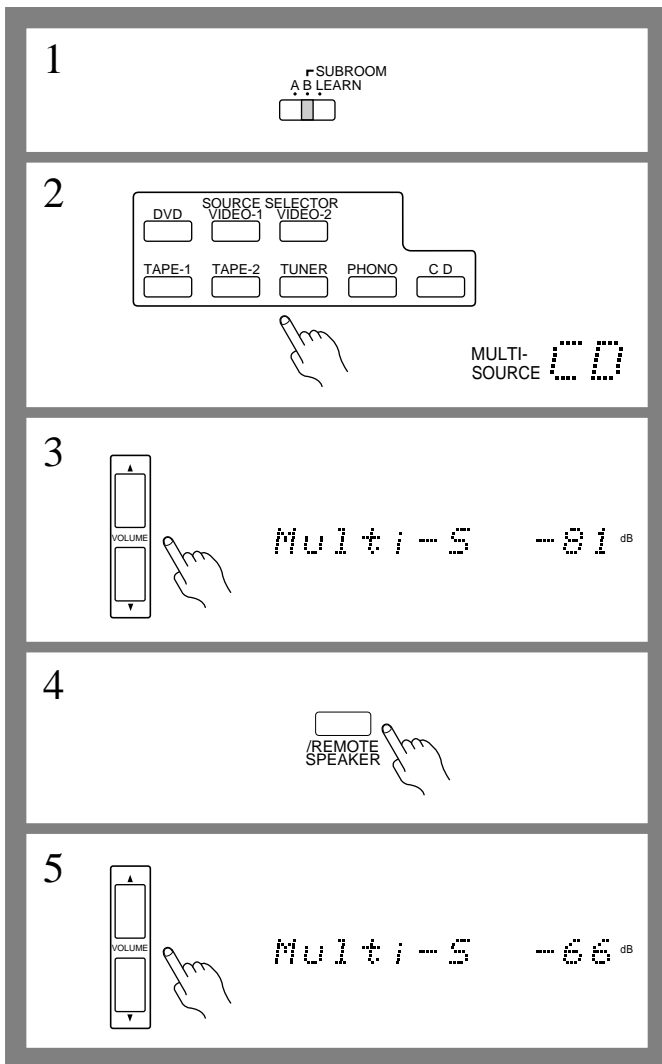
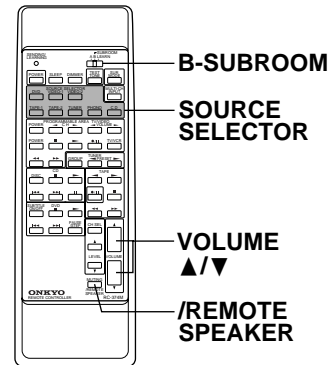
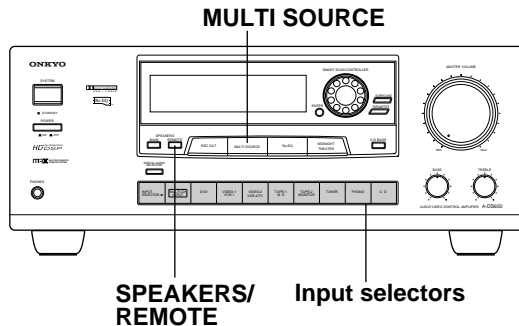

If the remote controller is used from the sub-room, but the components cannot be controlled, check the following.

- Use the buttons and switches on the component in the main room to check whether it is working properly. Then, use the remote controller to check whether the component is working properly. If it is not, refer to page 30.
- When operating a component that does not display Onkyo's **RI** mark, check that the emitter is directed toward that component.
- Check that the components are correctly connected.

Listening in another room

Using the remote controller:

In the main room:

1. Set the A/B-SUBROOM/LEARN selector switch to **B-SUBROOM**.
2. Press the **SOURCE SELECTOR** button for the desired source. The MULTI-SOURCE indicator lights up and the display indicates the input source.
 - You cannot select MULTI-CH INPUT.
3. Press the **VOLUME ▲** or **▼** button to set the **MULTI SOURCE** level to its minimum (between **-81** and **-79 dB**). MULTI-S and the level are indicated on the display for three seconds.
4. Press the **REMOTE SPEAKER** selector button. The REMOTE indicator lights up.

You can perform steps 1 and 2 on the amplifier instead of the remote controller.

1. Press the **MULTI SOURCE** button. The REC OUT indicator turns off and the MULTI-SOURCE indicator flashes for eight seconds.
2. While the MULTI-SOURCE indicator is flashing, press the **input selector** button to select the desired source.
 - If you press the input selector button while the indicator is turned off, the main room source will change.

In the sub-room:

5. Direct the remote controller toward the **Remote Sensor**. The remote controller can be used from the sub-room to select the source, adjust the volume, and turn on or off the sub-room speakers.
6. Adjust the level using the **VOLUME ▲** and **▼** buttons on the remote controller.
 - Press the REMOTE SPEAKER button to lower the volume temporarily in the sub-room.
 - The sub-room output level ranges from the minimum of ($-\infty$ dB), **-81**, ... **-1**, to the maximum of (**+18 dB**).
 - If the MULTI SOURCE function is turned on while a Surround mode is selected, the Surround mode automatically switches to STEREO.
 - If the MULTI SOURCE function is turned on while the multi-channel input mode is selected, the multi-channel input mode automatically turns off and the sound signals (audio signal of the selected video input) are heard from the speakers.

NOTE:

- Before turning off the remote (sub-room), please lower the volume level to prevent high volume output for the next application or use.
- If you set the A/B-SUBROOM/LEARN selector switch on the remote controller to **A** and adjust the VOLUME control knob, the volume level of the speakers in the main room — not in the sub-room — will change.
- We recommend that you turn off SPEAKERS MAIN to save electricity if you are not using the A-DS650 in the main room.
- You cannot select MULTI-CH INPUT in the sub-room.
- If someone in the main room changes Surround mode while you are listening in the sub-room, the sub-room sound will be muted.

Troubleshooting guide

If a problem occurs, adjust the controls on the A-DS650 front panel to confirm that the remote controller is not malfunctioning nor has worn out batteries.

Trouble	Cause	Remedy
Power, then immediately no power.	<ul style="list-style-type: none"> The amplifier protection circuitry has been activated. 	<ul style="list-style-type: none"> Contact your Onkyo Service Center.
No power.	<ul style="list-style-type: none"> Power cord is disconnected. There is external noise in the computer circuits of this unit. AC fuse blown. 	<ul style="list-style-type: none"> Connect power cord. Turn the power button off and then on again or remove the AC plug from the outlet and then plug it again. Contact your Onkyo Service Center.
Power but no sound.	<ul style="list-style-type: none"> The TAPE-2 MONITOR indicator is lit. The MUTING indicator is lit. The connections are bad or incorrect. 	<ul style="list-style-type: none"> Press the TAPE-2 MONITOR button. Press the MUTING button on the remote controller. Check the input leads, speaker leads, pin plugs, etc.
No sound or very minimal sound from the center speaker.	<ul style="list-style-type: none"> The speaker wires are disconnected. Surround mode is set to HALL, LIVE, ARENA, STUDIO, or STEREO. The Center Speaker Setup is set to NON. 	<ul style="list-style-type: none"> Check the connection between the amplifier and the speaker. When HALL, LIVE, ARENA, or STUDIO is selected for the Surround mode, only the effect sound will be output from the center speaker. The sound level will be less compared to the sound level when the DOLBY PRO LOGIC is selected. Set the Center Speaker Setup to SML or LRG.
Hum or low-frequency noise.	<ul style="list-style-type: none"> Poor or no input ground. Poor or no phono motor ground. The input and output cables are positioned incorrectly. 	<ul style="list-style-type: none"> Check the outer conductor of the input plugs. Check for a proper ground connection. Adjust the placement of the cable to reduce hum.
Howling when the volume is turned up.	<ul style="list-style-type: none"> The turntable and speakers are too close to each other. 	<ul style="list-style-type: none"> Move them further away from each other.
Rough or scratchy sound; high range is not clear.	<ul style="list-style-type: none"> The pick-up stylus is worn. The stylus tip is dirty. The treble level is too high. 	<ul style="list-style-type: none"> Replace it. Clean it. Decrease the treble.
Multi-Room Remote System does not operate.	<ul style="list-style-type: none"> The connections are incorrect. The remote controller is not aimed at the sensor. The path between the remote controller and the sensor is blocked. 	<ul style="list-style-type: none"> Check the connections. Aim the remote controller at the A-DS650 remote control sensor. Remove the object blocking the path to the sensor.
When VIDEO-2 are selected, no video screen appears.	<ul style="list-style-type: none"> The connections are bad or incorrect. IPM is turned ON. 	<ul style="list-style-type: none"> Check the input leads, speaker leads, pin plugs, etc. Make sure you select VIDEO-2 and turn IPM off (See page 10).
Front panel controls function but remote controller does not.	<ul style="list-style-type: none"> There are no batteries in remote controller. The batteries are worn out. 	<ul style="list-style-type: none"> Insert batteries. Replace batteries.

Also refer to the respective owner's manual of the other components, e.g. video disc player, video cassette recorder, or TV/monitor.

Specifications

AMPLIFIER SECTION

Power Output

Continuous Power output

(DIN)

Front Main L/R channels: 100 W × 2 at 6 ohms

Center channels: 100 W at 6 ohms

Surround L/R channels: 100 W × 2 at 6 ohms

Front Remote L/R channels: 100 W × 2 at 6 ohms

Maximum Power output

(EIAJ)

Front Main L/R channels: 130 W × 2 at 6 ohms

Center channels: 130 W at 6 ohms

Surround L/R channels: 130 W × 2 at 6 ohms

Front Remote L/R channels: 130 W × 2 at 6 ohms

IM Distortion: 0.08% at rated power (Front)

Damping Factor: 60 at 8 ohms (Front)

Input Sensitivity/Impedance

PHONO: 2.5 mV/50 kohms

CD/TAPE 1, 2/VIDEO-1, 2, 200 mV/50 kohms

DVD, TUNER:

MULTI CHANNEL INPUT

(FRONT L/R, SUR-

ROUND L/R, CENTER): 200 mV/50 kohms

MULTI CHANNEL INPUT

(SUBWOOFER): 36 mV/50 kohms

Output Level/Impedance

REC OUT: 200 mV/2.2 kohms

PRE OUT: 1 V/2.2 kohms

Phono Overload: 120 mV RMS at 1 kHz, 0.5% T.H.D.

Frequency Response: 20 Hz to 30 kHz, ±1 dB (Surround OFF)

RIAA Deviation: 20 Hz to 20 kHz, ±0.8 dB

Tone Control

Bass: ±10 dB at 50 Hz

Treble: ±10 dB at 10 kHz

Signal-to-Noise Ratio

(Surround OFF)

Phono: 80 dB (IHF A, 5 mV input)

CD/Tape: 100 dB (IHF A)

Muting: -∞ dB

VIDEO SECTION

Input Sensitivity and Impedance

Video (Composite): 1 Vp-p/75 ohms

Output Level and Impedance

Video (Composite): 1 Vp-p/75 ohms

DIGITAL SECTION

Digital input sampling frequency: 32, 44.1, 48 kHz

Input sensitivity/impedance Coaxial: 0.5 Vp-p/75 ohms

GENERAL

Power Supply

AC 230 V, 50 Hz

AC 220-230 V and 120 V switchable,

50/60 Hz

Power Consumption: 410 W

Dimensions (W × H × D): 435 × 175 × 390 mm

17-1/8" × 6-7/8" × 15-3/8"

Weight: 11.8 kg

12.5 kg

REMOTE CONTROL (RC-374M)

Transmitter: Infrared

Signal range: Approx. 5 meters, 16 ft.

Power supply: Two "AA" batteries (1.5 V × 2)

Specifications and features are subject to change without notice.

Control positions and names

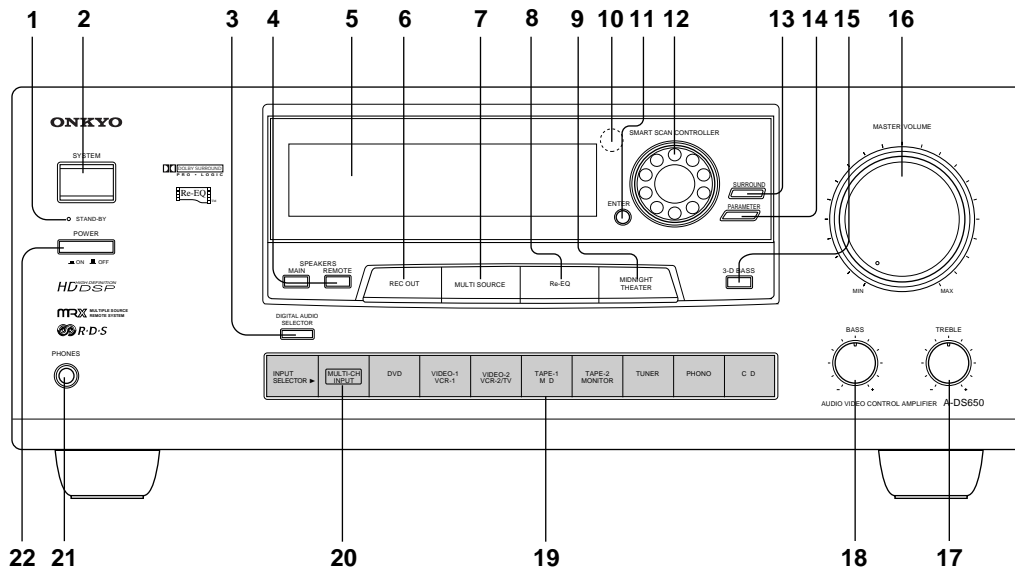

Display

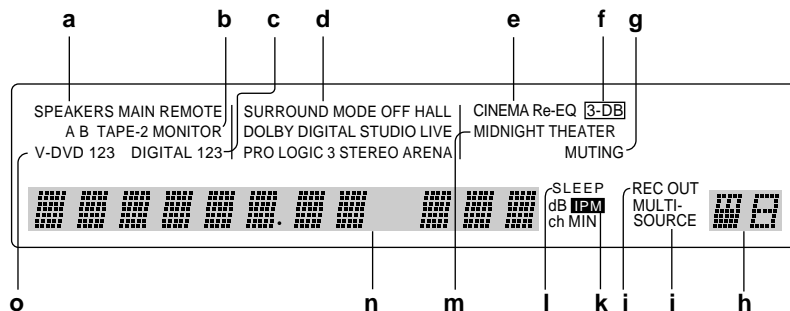

European model's front panel shown

Front panel

For more information on buttons or knobs, refer to the pages listed in the brackets ([]) below.

1. STAND-BY indicator [13]
2. SYSTEM button [13]
3. DIGITAL AUDIO SELECTOR button [17]
4. SPEAKERS MAIN/REMOTE selector buttons [16, 18, 29]
5. Display (Please refer to the "Display" illustration.)
6. REC OUT button [24]
7. MULTI SOURCE button [29]
8. Re-EQ button [22]
9. MIDNIGHT THEATER button [22]
10. Remote control sensor [6]
11. ENTER button [14, 15, 20~23]
12. SMART SCAN CONTROLLER jog dial [14, 15, 20~23]
13. SURROUND button [20~23]
14. PARAMETER button [20~23]
15. 3-D BASS button [16, 18]
16. MASTER VOLUME control knob [16, 17, 18]
17. TREBLE control knob [16, 18]
18. BASS control knob [16, 18]
19. Input selector buttons [16]
20. MULTI CHANNEL INPUT button [16, 23]
21. PHONES jack [17]
22. POWER switch [13]

Display

If a protective film on the surface of the display makes it difficult to read the display, remove the protective film.

- a. Speakers MAIN/REMOTE selector indicator
- b. Tape-2 Monitor indicator
- c. DIGITAL input indicator
- d. Surround mode indicators
- e. Cinema Re-Equalizer indicator
- f. 3-D Bass indicator
- g. Audio Muting indicator
- h. Source display (For Record out/ Multi-source out)
- i. Multi-Source indicator
- j. Record Out indicator
- k. Intelligent Power Management indicator
- l. Sleep indicator
- m. MIDNIGHT THEATER indicator
- n. Multi-function display
- o. Video input selector indicator

Remote controller RC-374M

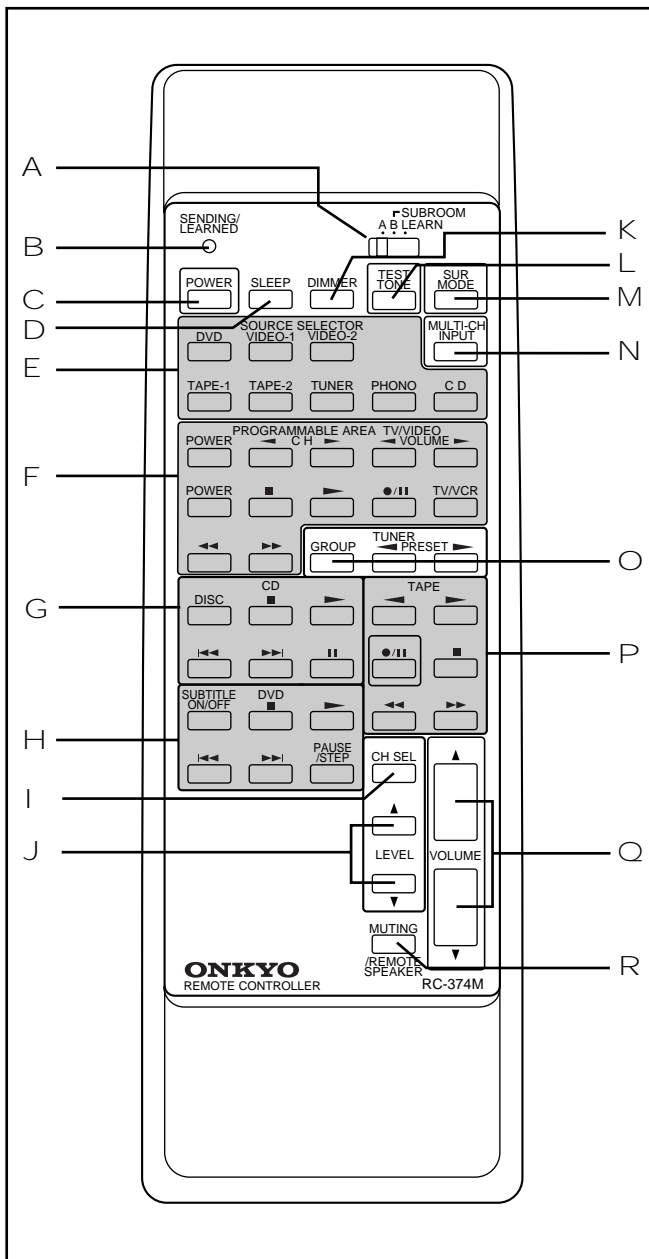

- A A/B/LEARN selector switch (A/B-SUB ROOM/LEARN) [26, 27, 29]**
 This switch features three functions as follows:
A — Set the switch to this position when you are using the remote controller in the main room. All buttons on the remote controller can be used. (The PROGRAMMABLE AREA TV/VIDEO buttons are used to store remote controller functions for TV and Video equipment.)
B-SUB ROOM — Set the switch to this position when you are using the remote controller in the sub room.
LEARN — Set the switch to this position when you are registering functions of another remote controller.
- B Sending/learned indicator [26, 27]**
- C Power button (POWER) [13]**
- D Sleep button (SLEEP) [19]**
- E Input selector buttons [16]**
 (Video-1, 2, DVD, PHONO, CD, TUNER, TAPE-1, TAPE-2)
- F PROGRAMMABLE AREA TV/VIDEO buttons [26, 27]**
 Use these buttons to store remote controller functions of TV and video equipment. For details, please refer to “Programming remote controller codes” on pages 26-27.
- G CD operation buttons**
 These buttons are used to operate an ONKYO CD player that bears the **RI** terminal. (Refer to page 7 for **RI** connection.)
- H DVD operation buttons**
 These buttons are used to operate an Onkyo DVD player that bears the **RI** terminal. (Refer to page 7 for **RI** connection.)
- I Channel selector button (CH. SEL) [15, 23]**
- J Level $\blacktriangle/\blacktriangledown$ buttons (LEVEL $\blacktriangle/\blacktriangledown$) [15, 23]**
- K DIMMER button (DIMMER) [18]**
 This button can be used to change the brightness of the display. The brightness changes in three steps: bright, medium, dim.
- L Test tone button (TEST) [15]**
- M Surround mode button (SURROUND MODE) [20]**
- N Multi channel input button [16, 23]**
- O Tuner operation buttons**
 These buttons are used to operate an ONKYO tuner that bears the **RI** terminal. (Refer to page 7 for **RI** connection.)
GROUP: — Group selector button
PRESET $\blacktriangle/\blacktriangledown$: — Preset memory down/up buttons
- P Tape operation buttons**
 These buttons control ONKYO cassette tape decks that can be remotely controlled. (Refer to page 7 for **RI** connection.)
- Q Volume buttons (VOLUME $\blacktriangle/\blacktriangledown$) [16, 18, 29]**
 To adjust the volume of the Front Main, Center, or Rear (Surround) speakers, set the A/B-SUB ROOM/LEARN switch to A, and use these buttons.
 To adjust the level of the Remote speakers (perhaps in another room), set the A/B-SUB ROOM/LEARN switch to B-SUB ROOM, and use these buttons.
- R Audio muting button (MUTING) [19]**
 (When the A/B/LEARN selector switch 1 is set to A)
REMOTE SPEAKER button (REMOTE SPEAKER) [29]
 (When the A/B/LEARN selector switch 1 is set to B)

MEMO

MEMO

ONKYO CORPORATION

Sales & Product Planning Div. : 2-1, Nisshin-cho, Neyagawa-shi, OSAKA 572-8540, JAPAN
Tel: 0720-31-8111 Fax: 0720-33-5222

ONKYO U.S.A. CORPORATION

200 Williams Drive, Ramesy, N.J. 07446, U.S.A.
Tel: 201-825-7950 Fax: 201-825-8150 E-mail: onkyo@onkyousa.com

ONKYO EUROPE ELECTRONICS GmbH

Industriestrasse 20, 82110 Germering, GERMANY
Tel: 089 84 93 20 Fax: 089 84 93 226 E-mail: info@onkyo.de

ONKYO EUROPE FRANCE BRANCH

Domaine Technologique de Saclay 4, Rue René Razel, SACLAY-91892
ORSAY CEDEX, FRANCE Tel: (1) 69 33 14 00 Fax: (1) 69 41 35 84

ONKYO CHINA LIMITED

Units 1111-1112 Metroplaza Tower II, 223 Hing Fong Road, Kwai Chung,
N.T., HONG KONG Tel: 852 2429 3118 Fax: 852 2428 9039

